

REVISION HISTORY			
REV	DATE	BY	DESCRIPTION
C	29JAN2018	ANT/JW	PRN: P2018-0167

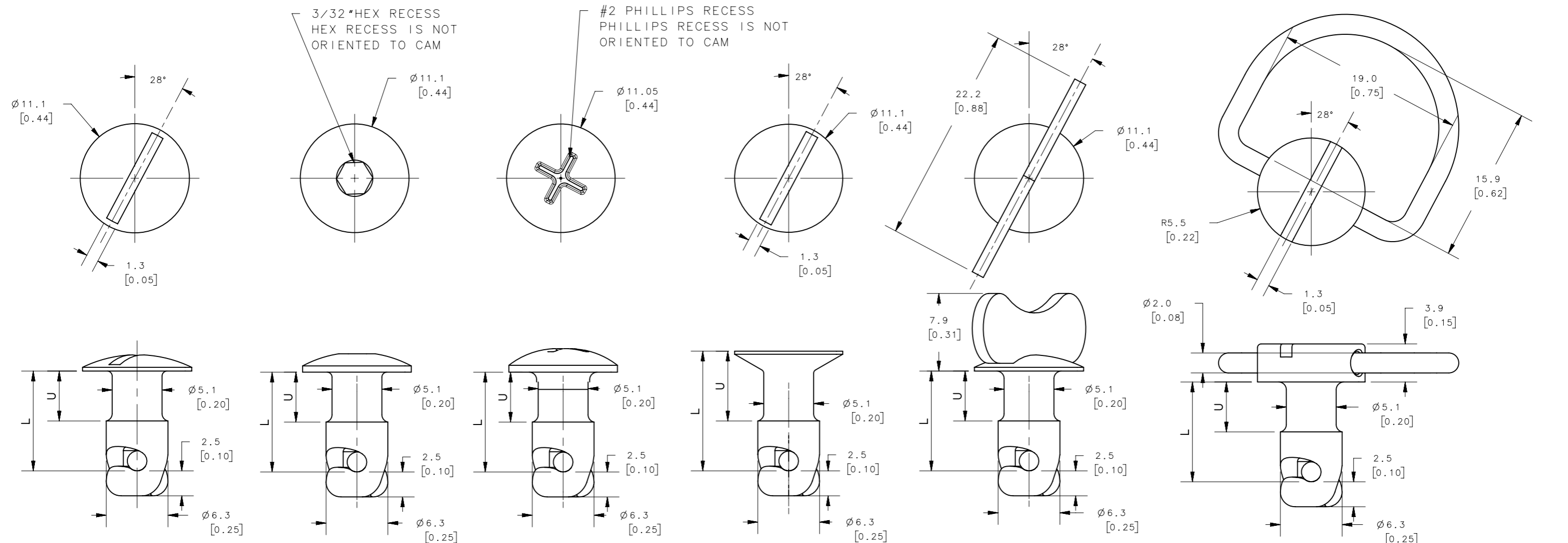

SLOT AJ **HEX RECESS** ASHJ **PHILLIPS RECESS** APRJ **FLUSH SLOT** FJ **WING HEAD** AJW **BAIL HEAD** BJR

SELECTION TABLE

K	U	L	K	U	L	K	U	L	K	U	L
25	1.91 [0.075]	6.35 [0.250]	85	12.70 [0.500]	21.59 [0.850]	145	15.24 [0.600]	36.83 [1.450]	205	15.24 [0.600]	52.07 [2.050]
30	2.54 [0.100]	7.62 [0.300]	90	15.24 [0.600]	22.86 [0.900]	150	15.24 [0.600]	38.10 [1.500]	210	15.24 [0.600]	53.34 [2.100]
35	3.81 [0.150]	8.89 [0.350]	95	15.24 [0.600]	24.13 [0.950]	155	15.24 [0.600]	39.37 [1.550]	215	15.24 [0.600]	54.61 [2.150]
40	5.08 [0.200]	10.16 [0.400]	100	15.24 [0.600]	25.40 [1.000]	160	15.24 [0.600]	40.64 [1.600]	220	15.24 [0.600]	55.88 [2.200]
45	5.72 [0.225]	11.43 [0.450]	105	15.24 [0.600]	26.67 [1.050]	165	15.24 [0.600]	41.91 [1.650]	225	15.24 [0.600]	57.15 [2.250]
50	6.35 [0.250]	12.70 [0.500]	110	15.24 [0.600]	27.94 [1.100]	170	15.24 [0.600]	43.18 [1.700]	230	15.24 [0.600]	58.42 [2.300]
55	6.99 [0.275]	13.97 [0.550]	115	15.24 [0.600]	29.21 [1.150]	175	15.24 [0.600]	44.45 [1.750]	235	15.24 [0.600]	59.69 [2.350]
60	7.62 [0.300]	15.24 [0.600]	120	15.24 [0.600]	30.48 [1.200]	180	15.24 [0.600]	45.72 [1.800]	240	15.24 [0.600]	60.96 [2.400]
65	8.89 [0.350]	16.51 [0.650]	125	15.24 [0.600]	31.75 [1.250]	185	15.24 [0.600]	46.99 [1.850]	245	15.24 [0.600]	62.23 [2.450]
70	8.89 [0.350]	17.78 [0.700]	130	15.24 [0.600]	33.02 [1.300]	190	15.24 [0.600]	48.26 [1.900]	250	15.24 [0.600]	63.50 [2.500]
75	10.16 [0.400]	19.05 [0.750]	135	15.24 [0.600]	34.29 [1.350]	195	15.24 [0.600]	49.53 [1.950]			
80	10.16 [0.400]	20.32 [0.800]	140	15.24 [0.600]	35.56 [1.400]	200	15.24 [0.600]	50.80 [2.000]			

PART NUMBER

LENGTH

ENTER NUMBER FROM SELECTION TABLE



HEAD STYLE

- AJ SLOT
- ASHJ HEX RECESS
- APRJ PHILIPS RECESS
- FJ FLUSH SLOT
- AJW WING HEAD
- BJR BAIL HEAD

MATERIAL/FINISH

- NO SUFFIX: STEEL ZINC PLATED WITH CLEAR CHROMATE FINISH
EX: D4-AJ4-30
- SS: STAINLESS STEEL, HEAT TREATED, PASSIVATED
EX: D4-AJ4-30SS
- FOR OTHER NON STANDARD FINISHS, REFER TO SOUTHCO SPECIFICATION J-D5-0-3
EX: D4-AJ4-30CBB

NOTE:
1. FOR STUDS WITH SHORT UNDERCUT OMIT 'J' FROM HEAD STYLE, EX: D4-AW4-30SS
UNDERCUT DIMENSION 'U' IS ALWAYS 2.03mm [0.080] FOR ALL STUD LENGTHS.

THIRD ANGLE PROJECTION			
			DESCRIPTION QUARTER TURN FASTENER, D4-H4
MILLIMETERS [IN]	SIZE A3	SYSTEM NX	DWG NO. J-D4-H4-K
TOLERANCES UNLESS OTHERWISE NOTED	PER ASME Y14.5M-1994	DRAWN BY YGC	DATE 09DEC2010
ALL DIMENSIONS WITHOUT TOLERANCES ARE FOR REFERENCE ONLY.	SCALE 2.5:1	SHEET 1 OF 1	