

Bellows suction cup (round)

<https://www.schmalz.com/10.01.06.02978>



FSGPL 100 NBR-55 G1/2-IG
DR

Part no.: 10.01.06.02978

Homepage > Vacuum Technology for Automation > Vacuum Components > Vacuum Suction Cups > FSGPL 100 NBR-55 G1/2-IG DR

Bellows suction cup (round) for large, heavy and uneven workpieces



Size: 100
Suction cup material:
Nitrile rubber NBR
Material hardness: 55 °Sh
Vacuum connection: G1/2-F
Nipple material: Steel
Number of folds: 1.5
Additional feature: Sealing ring

Design Data

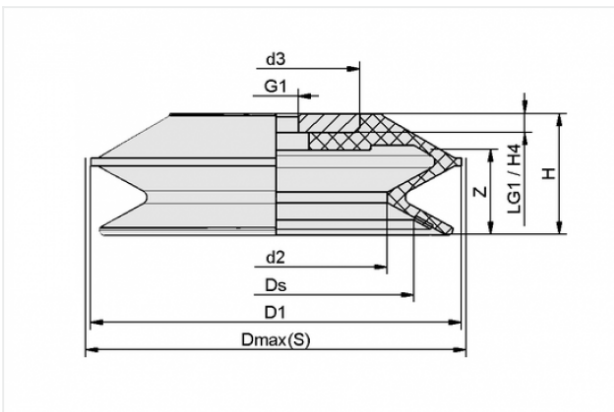

Attribute	Value
-----------	-------

d2	57.2 mm
----	---------

d3	44 mm
----	-------

D1	101 mm
----	--------

Dmax(S)	106.5 mm
---------	----------

Ds	67 mm
----	-------

G1	G1/2"-F
----	---------

H	43.3 mm
---	---------

H4	8 mm
----	------

LG1	8 mm
-----	------

Z	29.1 mm
---	---------

Contact to Schmalz

J. Schmalz GmbH | Johannes-Schmalz-Straße, 72293 Glatten, Deutschland | +49 7443 2403-102 | customercenter@schmalz.de

Technical Data

Attribute	Value
Volume	150 cm ³
Curve radius (min) (convex)	100 mm
Internal hose diameter (recom.)	12 mm
Size	100
Number of folds	1.5
Suction cup material	Nitrile rubber NBR
Material hardness	55 °Sh
Weight	154 g
