

Bellows suction cup (round)

<https://www.schmalz.com/10.01.06.01245>



FSG 20 HT1-60 G1/8-IG

Part no.: 10.01.06.01245

Homepage > Vacuum Technology for Automation > Vacuum Components > Vacuum Suction Cups > Bellows Suction Cups (Round) > Bellows

Suction Cups FSG (2.5 Folds) > FSG 20 HT1-60 G1/8-IG

Bellows suction cup (round) for very uneven workpieces



Size: 20
Suction cup material:
High temp material HT1
Material hardness: 60 °Sh
Material property: imprint-free
Nipple material: Aluminium
Vacuum connection: G1/8-F
Number of folds: 2.5

Design Data

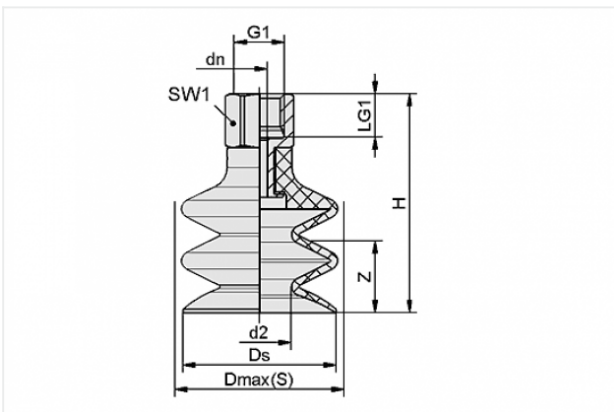

Attribute	Value
-----------	-------

d2	10.5 mm
----	---------

dn	3.5 mm
----	--------

Dmax(S)	21 mm
---------	-------

Ds	20 mm
----	-------

G1	G1/8"-F
----	---------

H	34.1 mm
---	---------

LG1	8 mm
-----	------

SW1	14 mm
-----	-------

Z	9 mm
---	------

Contact to Schmalz

J. Schmalz GmbH | Johannes-Schmalz-Straße, 72293 Glatten, Deutschland | +49 7443 2403-102 | customercenter@schmalz.de

Technical Data

Attribute	Value
Suction force	5.2 N
Pull-off force	12.1 N
Volume	2.298 cm ³
Curve radius (min) (convex)	30 mm
Internal hose diameter (recom.)	4 mm
Size	20
Number of folds	2.5
Suction cup material	High temp material HT1
Material hardness	60 °Sh
Weight	6.4 g
Product family	FSG

Note:

- Suction force: The specified suction forces are theoretical values at a vacuum of -0.6 bar and with a smooth, dry workpiece surface - they do not include a safety factor
- Pull-off force: The pull-off force of the versions made of natural rubber is reduced by about 40%
- Hose diameter: The recommended hose diameter refers to a hose length of approx. 2 m

Spare Parts

Contact to Schmalz

**SA-NIP N016 G1/8-IG DN350**

Part no. 10.01.06.05731

Suction cup connection nipple

Nipple: N 016

Thread G1: G1/8-F

Overall length: 18.5 mm

Fitting length: 12 mm

Nominal size: 3,50 mm

Material: Aluminium

**FG 20 HT1-60 N016**

Part no. 10.01.06.01253

Bellows suction cup (round) for very uneven workpieces

Size: 20

Suction cup material:

High temp material HT1

Material hardness: 60 °Sh

Number of folds: 2.5

Material property: imprint-free

Accessories**FD 16 120**

Part no. 10.01.06.02565

Filter disc

External diameter D: 16 mm

Filter pore size: 120 µm

for: Bellows suction pad

Size: FG20/FGA20



SPI 21 PEEK

Part no. 10.01.06.03285

Insert disc for preventing film from being drawn in

Size: 21

Material: Polyetheretherketon

Application: FG20/FGA22