

Bellows suction cup (round)

<https://www.schmalz.com/10.01.06.00969>



FSG 18 HT1-60 M5-AG

Part no.: 10.01.06.00969

Homepage > Vacuum Technology for Automation > Vacuum Components > Vacuum Suction Cups > Bellows Suction Cups (Round) > Bellows Suction Cups FSG (2.5 Folds) > FSG 18 HT1-60 M5-AG

Bellows suction cup (round) for very uneven workpieces



Size: 18
Suction cup material:
High temp material HT1
Material hardness: 60 °Sh
Material property: imprint-free
Nipple material: Aluminium
Vacuum connection: M5-M
Number of folds: 2.5

Design Data

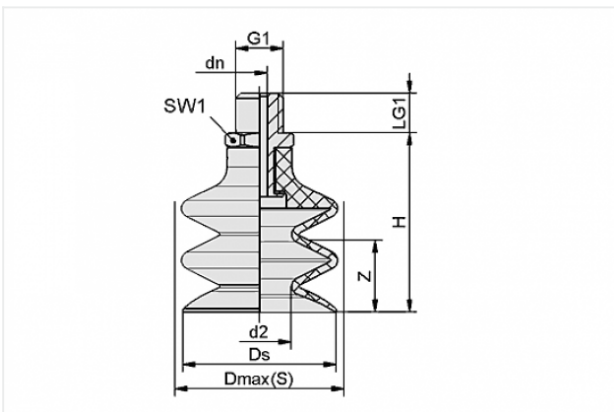

Attribute	Value
-----------	-------

d2	8 mm
----	------

dn	2.5 mm
----	--------

Dmax(S)	19 mm
---------	-------

Ds	17.2 mm
----	---------

G1	M5-M
----	------

H	27.6 mm
---	---------

LG1	5 mm
-----	------

SW1	7 mm
-----	------

Z	9 mm
---	------

Contact to Schmalz

J. Schmalz GmbH | Johannes-Schmalz-Straße, 72293 Glatten, Deutschland | +49 7443 2403-102 | customercenter@schmalz.de

Technical Data

Attribute	Value
Suction force	3.02 N
Pull-off force	8.5 N
Volume	1.35 cm ³
Curve radius (min) (convex)	20 mm
Internal hose diameter (recom.)	2 mm
Size	18
Number of folds	2.5
Suction cup material	High temp material HT1
Material hardness	60 °Sh
Weight	2.9 g
Product family	FSG

Note:

- Suction force: The specified suction forces are theoretical values at a vacuum of -0.6 bar and with a smooth, dry workpiece surface - they do not include a safety factor
- Pull-off force: The pull-off force of the versions made of natural rubber is reduced by about 40%
- Hose diameter: The recommended hose diameter refers to a hose length of approx. 2 m

Spare Parts

Contact to Schmalz



SA-NIP N016 M5-AG DN250

Part no. 10.01.06.00123

Suction cup connection nipple

Nipple: N 016

Thread G1: M5-M

Overall length: 16 mm

Fitting length: 5 mm

Nominal size: 2,50 mm

Material: Aluminium



FG 18 HT1-60 N016

Part no. 10.01.06.00881

Bellows suction cup (round) for very uneven workpieces

Size: 18

Suction cup material:

High temp material HT1

Material hardness: 60 °Sh

Number of folds: 2.5

Material property: imprint-free

Accessories



SPI 17 PEEK

Part no. 10.01.06.03283

Insert disc for preventing film from being drawn in

Size: 17

Material: Polyetheretherketon

Application: FG18/FGA16