

Bellows suction cup (round)

<https://www.schmalz.com/10.01.06.00039>



FSG 14 SI-55 M5-AG

Part no.: 10.01.06.00039

Homepage > Vacuum Technology for Automation > Vacuum Components > Vacuum Suction Cups > Bellows Suction Cups (Round) > Bellows Suction Cups FSG (2.5 Folds) > FSG 14 SI-55 M5-AG

Bellows suction cup (round) for very uneven workpieces



Size: 14
Suction cup material: Silicone SI
Material hardness: 55 °Sh
Material characteristics:
FDA-compatible
Nipple material: Aluminium
Vacuum connection: M5-M
Number of folds: 2.5

Design Data

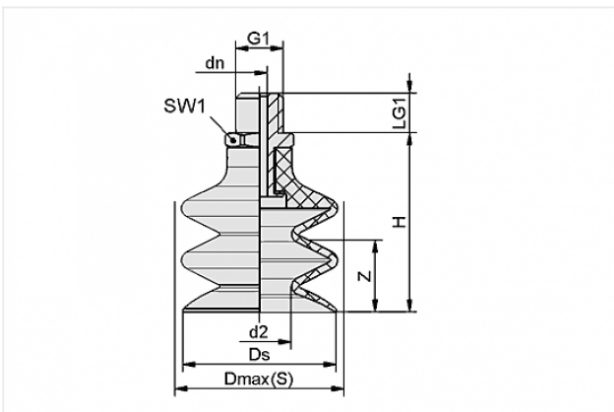

Attribute	Value
-----------	-------

d2	5.4 mm
----	--------

dn	2.5 mm
----	--------

Dmax(S)	15.5 mm
---------	---------

Ds	14.5 mm
----	---------

G1	M5-M
----	------

H	27.8 mm
---	---------

LG1	5 mm
-----	------

SW1	7 mm
-----	------

Z	9 mm
---	------

Contact to Schmalz

J. Schmalz GmbH | Johannes-Schmalz-Straße, 72293 Glatten, Deutschland | +49 7443 2403-102 | customercenter@schmalz.de

Technical Data

Attribute	Value
Suction force	1.37 N
Pull-off force	5.7 N
Volume	0.975 cm ³
Curve radius (min) (convex)	15 mm
Internal hose diameter (recom.)	2 mm
Size	14
Number of folds	2.5
Suction cup material	Silicone SI
Material hardness	55 °Sh
Weight	2.6 g
Product family	FSG

Note:

- Suction force: The specified suction forces are theoretical values at a vacuum of -0.6 bar and with a smooth, dry workpiece surface - they do not include a safety factor
- Pull-off force: The pull-off force of the versions made of natural rubber is reduced by about 40%
- Hose diameter: The recommended hose diameter refers to a hose length of approx. 2 m

Spare Parts

Contact to Schmalz



SA-NIP N016 M5-AG DN250

Part no. 10.01.06.00123

Suction cup connection nipple

Nipple: N 016

Thread G1: M5-M

Overall length: 16 mm

Fitting length: 5 mm

Nominal size: 2,50 mm

Material: Aluminium



FG 14 SI-55 N016

Part no. 10.01.06.00057

Bellows suction cup (round) for very uneven workpieces

Size: 14

Suction cup material: Silicone SI

Material hardness: 55 °Sh

Material characteristics:

FDA-compatible

Number of folds: 2.5

Accessories



SPI 14 PEEK

Part no. 10.01.06.03282

Insert disc for preventing film from being drawn in

Size: 14

Material: Polyetheretherketon

Application: FG12/FG14/FGA14