

Bellows suction cup (round)

<https://www.schmalz.com/10.01.06.00426>



FGA 33 NK-45 N018

Part no.: 10.01.06.00426

Homepage > Vacuum Technology for Automation > Vacuum Components > Vacuum Suction Cups > Bellows Suction Cups (Round) > FGA 33 NK-45 N018

Bellows suction cup (round) with optimal adaptation to uneven surfaces



Size: 33
Suction cup material:
Natural Rubber NK
Material hardness: 45 °Sh
Number of folds: 1.5

Design Data

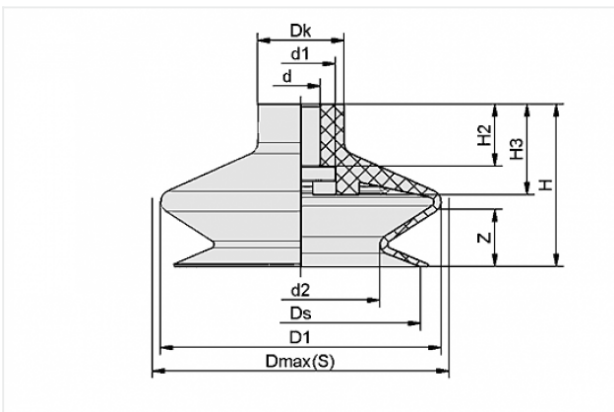

Attribute	Value
-----------	-------

d	8 mm
---	------

d1	16 mm
----	-------

d2	17 mm
----	-------

D1	36 mm
----	-------

Dk	18 mm
----	-------

Dmax(S)	38 mm
---------	-------

Ds	30 mm
----	-------

H	27 mm
---	-------

H2	13 mm
----	-------

H3	14 mm
----	-------

Z	9 mm
---	------

Contact to Schmalz

J. Schmalz GmbH | Johannes-Schmalz-Straße, 72293 Glatten, Deutschland | +49 7443 2403-102 | customercenter@schmalz.de

Technical Data

Attribute	Value
Number of folds	1.5
Suction force	13.6 N
Size	33
Suction cup material	Natural Rubber NK
Weight	7 g
Curve radius (min) (convex)	40 mm
Product family	FGA

Accessories



SA-NIP N018 G1/4-AG DN440

Part no. 10.01.06.01065

Suction cup connection nipple

Nipple: N 018

Thread G1: G1/4-M

Overall length: 28.8 mm

Fitting length: 4 mm

Nominal size: 4,40 mm

Material: Aluminium

Spanner size SW2: 5 mm



SA-NIP N018 G1/4-IG DN440

Part no. 10.01.06.01066

Suction cup connection nipple

Nipple: N 018

Thread G1: G1/4-F

Overall length: 28.8 mm

Fitting length: 15 mm

Nominal size: 4,40 mm

Material: Aluminium

Spanner size SW2: 5 mm

Contact to Schmalz



SPI 32 PEEK

Part no. 10.01.06.03287

Insert disc for preventing film from being drawn in

Size: 32

Material: Polyetheretherketon

Application: FG32/FGA33