

# Multi-Base VC-M-BV 265x170x209

<https://www.schmalz.com/10.01.12.02050>



Part no.: 10.01.12.02050

Homepage > Vacuum Clamping Technology > Clamping Solutions for Woodworking > Clamping Solutions for Manual Work > Accessories and Spare Parts > VC-M-BV 265x170x209

## Turning and slewing device Base



Length L: 265 mm  
Width B: 170 mm  
Height H: 209 mm

## Design Data

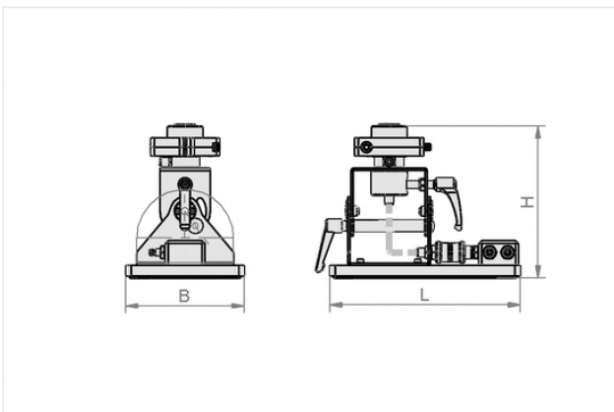

Attribute	Value
-----------	-------

B	170 mm
---	--------

H	209 mm
---	--------

L	265 mm
---	--------

## Technical Data

Attribute	Value
-----------	-------

Weight	7.34 kg
--------	---------

## Contact to Schmalz

J. Schmalz GmbH | Johannes-Schmalz-Straße, 72293 Glatten, Deutschland | +49 7443 2403-102 | [customercenter@schmalz.de](mailto:customercenter@schmalz.de)

## Accessories



### **VC-M-SPV 160x160**

Part no. 10.01.12.01853  
Multi-Clamp Suction plate  
Length L: 160 mm  
Width B: 160 mm



### **VC-M-SPV 300x100**

Part no. 10.01.12.02053  
Multi-Clamp Suction plate  
Length L: 300 mm  
Width B: 100 mm



### **VC-M-SPV 200x55**

Part no. 10.01.12.02009  
Multi-Clamp Suction plate  
Length L: 200 mm  
Width B: 55 mm



**VC-M-SPV 210**

Part no. 10.01.12.02008

Multi-Clamp Suction plate

External diameter D: 210 mm



**VC-M-PU 4 230V-AC**

Part no. 10.01.12.02040

Multi-Clamp Vacuum pump

Current type: 1-phase AC 230V

Voltage: 230V - AC

Vacuum (max): -850 mbar

Suction rate: 4 m<sup>3</sup>/h

Nominal size: 9 mm



**VC-M-PU 4 110V-AC**

Part no. 10.01.12.02051

Multi-Clamp Vacuum pump

Current type: 1-phase AC 110V

Voltage: 110V - AC

Vacuum (max): -850 mbar

Suction rate: 4 m<sup>3</sup>/h

Nominal size: 9 mm



**FU 5 3/2 -**

Part no. 10.01.12.02055

Foot-operated valve for control of compressed air and vacuum

Nominal size: 5 mm

Function: 3/2-way valve

Thread G1: G1/4-F

with: None



**REIB-INS 8.1x18 VC-M**

Part no. 10.01.12.02000

Friction Pad

External diameter D: 8.1 mm

Height H: 18 mm

for: Multi-Clamp



**DI-PROF 8x10.5 MOS EPDM-15**

Part no. 10.01.12.02056

Sealing section for construction of specific gripper solutions

Width B: 8 mm

Height H: 10.5 mm

Material-Type: Foam rubber

Sealing material: EPDM

Material hardness: 15 °Sh



**ZUB VC-M-V**

Part no. 10.01.12.02054

Accessories

for: Multi-Clamp