

Quadbase

ISQB-T 175x175x22

<https://www.schmalz.com/10.01.15.00153>



Part no.: 10.01.15.00153

Homepage > Vacuum Clamping Technology > Clamping Solutions for Woodworking > Modernization of CNC Machining Centers > Innospann Steel-Plate-T > ISQB-T 175x175x22

Quadbase for Steelplate-T



Length: 175 mm

Width: 175 mm

Height: 22 mm

Design Data

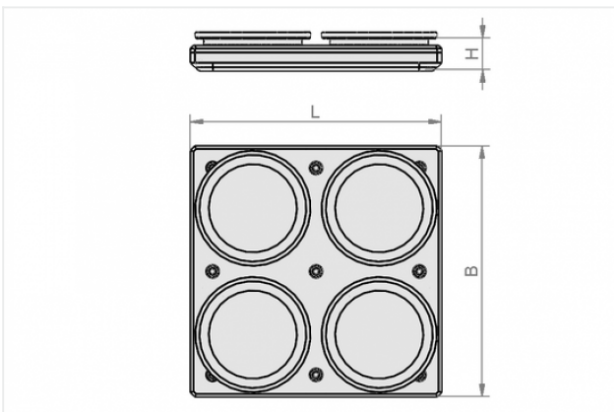

Attribute	Value
-----------	-------

B	175 mm
---	--------

H	22 mm
---	-------

L	175 mm
---	--------

Accessories

Contact to Schmalz

J. Schmalz GmbH | Johannes-Schmalz-Straße, 72293 Glatten, Deutschland | +49 7443 2403-102 | customercenter@schmalz.de



IS-CUP Cup 1 80x80x30

Part no. 10.01.15.00003

Suction cup for Innospann

Dimensions (LxB): 80 x 80 mm

Height H: 30 mm



IS-CUP Cup 2 80x40x30

Part no. 10.01.15.00004

Suction cup for Innospann

Dimensions (LxB): 80 x 40 mm

Height H: 30 mm



IS-CUP Cup 3 80x28x30

Part no. 10.01.15.00005

Suction cup for Innospann

Dimensions (LxB): 80 x 28 mm

Height H: 30 mm