

Monobase ISMB-T 80x80x42

Part no.: 10.01.15.00154

<https://www.schmalz.com/10.01.15.00154>



Homepage > Vacuum Clamping Technology > Clamping Solutions for Woodworking > Modernization of CNC Machining Centers > Innospann Steel-Plate-T > ISMB-T 80x80x42

Monobase-T for steel plate T



Length L: 80 mm

Width B: 80 mm

Height H: 42 mm

Design Data

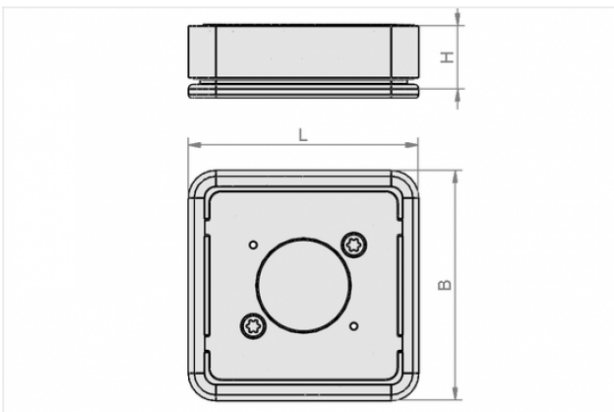

Attribute	Value
-----------	-------

B	80 mm
---	-------

H	42 mm
---	-------

L	80 mm
---	-------

Technical Data

Attribute	Value
-----------	-------

Weight	0.266 kg
--------	----------

Contact to Schmalz

J. Schmalz GmbH | Johannes-Schmalz-Straße, 72293 Glatten, Deutschland | +49 7443 2403-102 | customercenter@schmalz.de

Accessories



IS-CUP Cup 1 80x80x30

Part no. 10.01.15.00003

Suction cup for Innospann

Dimensions (LxB): 80 x 80 mm

Height H: 30 mm



IS-CUP Cup 2 80x40x30

Part no. 10.01.15.00004

Suction cup for Innospann

Dimensions (LxB): 80 x 40 mm

Height H: 30 mm



IS-CUP Cup 3 80x28x30

Part no. 10.01.15.00005

Suction cup for Innospann

Dimensions (LxB): 80 x 28 mm

Height H: 30 mm