

Steel-Plate

ISST-T 1000x1000x3

<https://www.schmalz.com/10.01.14.99995>



Part no.: 10.01.14.99995

Homepage > Vacuum Clamping Technology > Clamping Solutions for Woodworking > Modernization of CNC Machining Centers > Innospann Steel-Plate-T > ISST-T 1000x1000x3

Steelplate T with solenoid valves for clamping tables with grid



Length L: 1000 mm
Width B: 1000 mm
Height H: 3 mm

Design Data

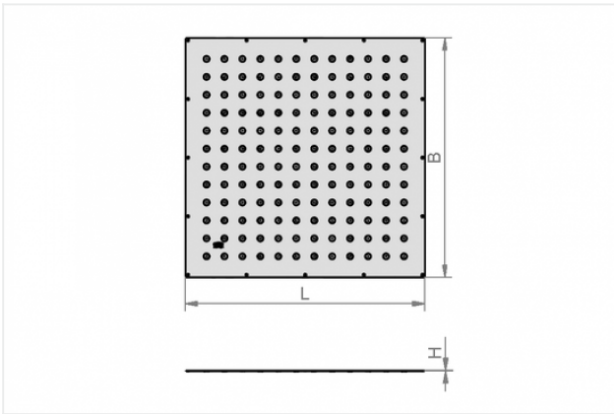

Attribute	Value
-----------	-------

B	1000 mm
---	---------

H	3 mm
---	------

L	1000 mm
---	---------

Technical Data

Attribute	Value
-----------	-------

Weight	23 kg
--------	-------

Contact to Schmalz

J. Schmalz GmbH | Johannes-Schmalz-Straße, 72293 Glatten, Deutschland | +49 7443 2403-102 | customercenter@schmalz.de

Accessories



ISMB-T 80x80x22

Part no. 10.01.15.00145

Monobase-T for steel plate T

Length L: 80 mm

Width B: 80 mm

Height H: 22 mm



ISMB-T 80x80x42

Part no. 10.01.15.00154

Monobase-T for steel plate T

Length L: 80 mm

Width B: 80 mm

Height H: 42 mm

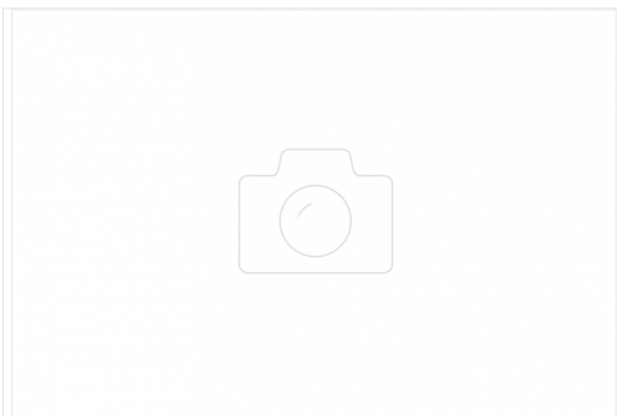

ISMB-T 80x80x67

Part no. 10.01.15.00155

Monobase-T for steel plate T

Length L: 80 mm

Width B: 80 mm

Height H: 67 mm



ISCUP Cup 1 80x80x30

Part no. 10.01.15.00003

Suction cup for Innospann

Dimensions (LxB): 80 x 80 mm

Height H: 30 mm



ISCUP Cup 2 80x40x30

Part no. 10.01.15.00004

Suction cup for Innospann

Dimensions (LxB): 80 x 40 mm

Height H: 30 mm



ISCUP Cup 3 80x28x30

Part no. 10.01.15.00005

Suction cup for Innospann

Dimensions (LxB): 80 x 28 mm

Height H: 30 mm



ISMC-ST 175x175x52 12-80

Part no. 10.01.15.00273

Mechanical clamp for narrow and frame parts, for Steel-Plate-T

Basic area: 175 x 175 mm mm

Height H: 52 mm

Stroke Z: 10 mm

Clamping range: 12.0 ... 80.0 mm

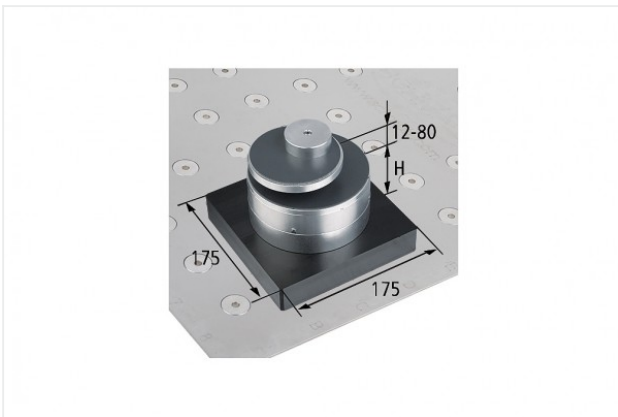

ISMC-ST 175x175x72 12-80

Part no. 10.01.15.00272

Mechanical clamp for narrow and frame parts, for Steel-Plate-T

Basic area: 175 x 175 mm mm

Height H: 72 mm

Stroke Z: 10 mm

Clamping range: 12.0 ... 80.0 mm

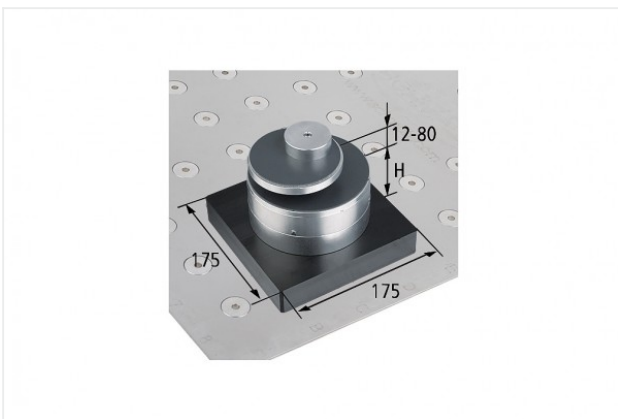

ISMC-ST 175x175x97 12-80

Part no. 10.01.15.00256

Mechanical clamp for narrow and frame parts, for Steel-Plate-T

Basic area: 175 x 175 mm mm

Height H: 97 mm

Stroke Z: 10 mm

Clamping range: 12.0 ... 80.0 mm