

Vacuum gauge

VAM 100 V250 U

Part no.: 10.07.02.00001

<https://www.schmalz.com/10.07.02.00001>



Homepage > Vacuum Technology for Automation > Vacuum Components > Switches and System Monitoring > Measuring and Control Devices >

Manometers VAM > VAM 100 V250 U

Vacuum gauge (manometer) for analogue measurement and monitoring of the vacuum



External diameter D: 100 mm
Measuring range: -0.25 ... 0.00 bar
Shape: Connection at bottom
Vacuum connection: G1/2-M

Design Data

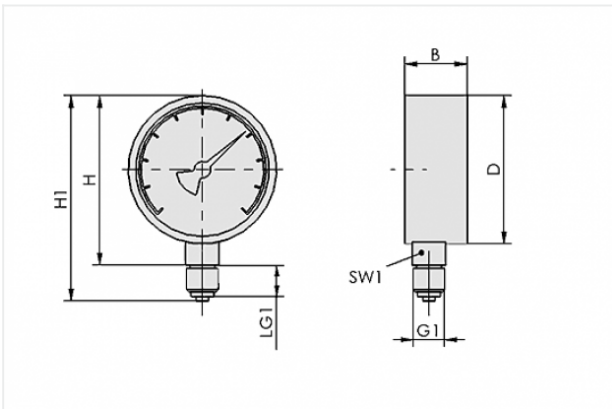

Attribute	Value
-----------	-------

B	87 mm
---	-------

D	100 mm
---	--------

G1	G1/2"-M
----	---------

H	112 mm
---	--------

H1	142 mm
----	--------

LG1	25 mm
-----	-------

SW1	22 mm
-----	-------

Technical Data

Contact to Schmalz

J. Schmalz GmbH | Johannes-Schmalz-Straße, 72293 Glatten, Deutschland | +49 7443 2403-102 | customercenter@schmalz.de

Attribute	Value
Shape	Connection at bottom
Operating pressure	-0,25...0 bar
Weight	526 g
