

Vacuum gauge

VAM 67 V H-SE

Part no.: 10.07.02.00016

<https://www.schmalz.com/10.07.02.00016>



Homepage > Vacuum Technology for Automation > Vacuum Components > Switches and System Monitoring > Measuring and Control Devices >

Manometers VAM > VAM 67 V H-SE

Vacuum gauge (manometer) for analogue measurement and monitoring of the vacuum



External diameter D: 67 mm
Measuring range: -1.00 ... 0.00 bar
Shape: For panel mounting
Vacuum connection: G1/8-M

Design Data

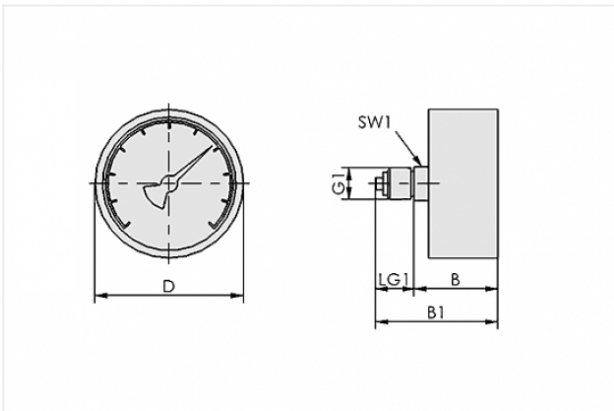

Attribute	Value
B	39.5 mm
B1	59 mm
D	67 mm
G1	G1/8"-M
H	75.5 mm
LG1	10 mm
SW1	14 mm

Technical Data

Contact to Schmalz

J. Schmalz GmbH | Johannes-Schmalz-Straße, 72293 Glatten, Deutschland | +49 7443 2403-102 | customercenter@schmalz.de

Attribute	Value
Shape	For panel mounting
Operating pressure	-1...0 bar
Weight	184 g
