

Check valve

SVK G1/4-IG

Part no.: 10.05.03.00035

<https://www.schmalz.com/10.05.03.00035>



Homepage > Vacuum Technology for Automation > Vacuum Components > Valve Technology > Check Valves and Flow Restrictors > Check Valves
SVK, SVKG, SVV > SVK G1/4-IG

Check valve for deactivation of unused suction pads



Thread 1: G1/4-M

Thread 2: G1/4-F

Design Data

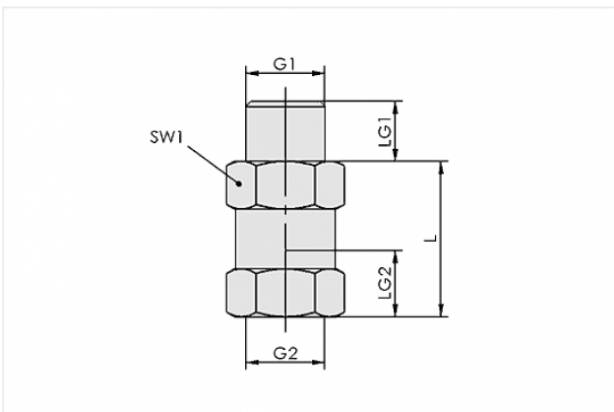

| Attribute | Value |
|-----------|-------|
|-----------|-------|

| | |
|----|---------|
| G1 | G1/4"-M |
|----|---------|

| | |
|----|---------|
| G2 | G1/4"-F |
|----|---------|

| | |
|---|-------|
| L | 26 mm |
|---|-------|

| | |
|-----|-------|
| LG1 | 10 mm |
|-----|-------|

| | |
|-----|-------|
| LG2 | 11 mm |
|-----|-------|

| | |
|-----|-------|
| SW1 | 17 mm |
|-----|-------|

Technical Data

| Attribute | Value |
|-----------|-------|
|-----------|-------|

| | |
|--------------------------------------|------------------------|
| Evacuation rate for $p_u = -0,3$ bar | 0.17 m ³ /h |
|--------------------------------------|------------------------|

| | |
|--------------------------------------|-----------|
| Evacuation rate for $p_u = -0,3$ bar | 2.9 l/min |
|--------------------------------------|-----------|

Contact to Schmalz

J. Schmalz GmbH | Johannes-Schmalz-Straße, 72293 Glatten, Deutschland | +49 7443 2403-102 | customercenter@schmalz.de



| Attribute | Value |
|-----------------------------------|------------------------|
| Evacuation rate for pu = -0,6 bar | 0.2 m ³ /h |
| Evacuation rate for pu = -0,6 bar | 3.4 l/min |
| Flow rate (max) | 20.4 m ³ /h |
| Flow rate (max) | 340 l/min |
| Weight | 17.5 g |
