

Check valve

SVK M5-IG

Part no.: 10.05.03.00033

<https://www.schmalz.com/10.05.03.00033>



Homepage > Vacuum Technology for Automation > Vacuum Components > Valve Technology > Check Valves and Flow Restrictors > Check Valves
SVK, SVKG, SVV > SVK M5-IG

Check valve for deactivation of unused suction pads



Thread 1: M5-M

Thread 2: M5-F

Design Data

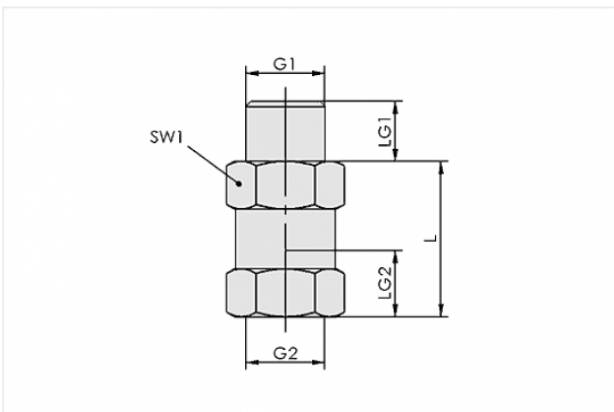

Attribute	Value
-----------	-------

G1	M5-M
----	------

G2	M5-F
----	------

L	15.5 mm
---	---------

LG1	4.5 mm
-----	--------

LG2	4.5 mm
-----	--------

SW1	8 mm
-----	------

Technical Data

Attribute	Value
-----------	-------

Evacuation rate for $p_u = -0,3$ bar	0.07 m ³ /h
--------------------------------------	------------------------

Evacuation rate for $p_u = -0,3$ bar	1.2 l/min
--------------------------------------	-----------

Contact to Schmalz

J. Schmalz GmbH | Johannes-Schmalz-Straße, 72293 Glatten, Deutschland | +49 7443 2403-102 | customercenter@schmalz.de



Attribute	Value
Evacuation rate for $p_u = -0,6$ bar	0.08 m ³ /h
Evacuation rate for $p_u = -0,6$ bar	1.3 l/min
Flow rate (max)	4.8 m ³ /h
Flow rate (max)	80 l/min
Weight	2.2 g