

# Solenoid valve

## EMV 15 230V-AC 3/2 NO

<https://www.schmalz.com/10.05.01.00073>



Part no.: 10.05.01.00073

Homepage > Vacuum Technology for Automation > Vacuum Components > Valve Technology > Solenoid Valves > Solenoid Valves EMV > EMV 15 230V-AC 3/2 NO

## Solenoid valve EMV for direct control of vacuum and compressed air



Nominal size: 15 mm  
Voltage: 230V - AC  
Function: 3/2-way valve  
Control: Normally open  
Connecting thread: G3/4-F  
Power consumption (DC): 38.4 W

### Design Data

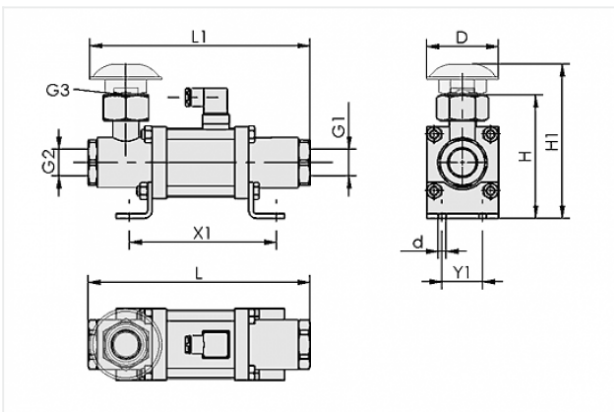

Attribute	Value
-----------	-------

d	6.5 mm
---	--------

D	80 mm
---	-------

G1	G3/4"-F
----	---------

G2	G3/4"-F
----	---------

G3	G3/4"-F
----	---------

H	114 mm
---	--------

H1	140 mm
----	--------

L	209 mm
---	--------

L1	211 mm
----	--------

X1	133 mm
----	--------

Y1	40 mm
----	-------

### Contact to Schmalz

J. Schmalz GmbH | Johannes-Schmalz-Straße, 72293 Glatten, Deutschland | +49 7443 2403-102 | [customercenter@schmalz.de](mailto:customercenter@schmalz.de)

## Technical Data

Attribute	Value
Nominal size	15 mm
Control	Normally open
Nominal flow rate	566.7 l/min
Nominal flow rate	34 m <sup>3</sup> /h
Power consumption (DC)	38.4 W
Voltage	230V - AC
Closing time	80 ms
Weight	4.665 kg

## Spare Parts



### FAS 80x39 G3/4-AG

Part no. 10.05.01.00062

Filter with mounting kit

External diameter D: 80 mm

Length L: 39 mm

Thread G1: G3/4-M