

# Vacuum pump EVE-TR-X 40 AC3 F

Part no.: 10.03.01.00219

<https://www.schmalz.com/10.03.01.00219>



Homepage > Vacuum Technology for Automation > Vacuum Components > Vacuum Generators > Vacuum Pumps > Dry-Running Vacuum Pumps  
EVE-TR X > EVE-TR-X 40 AC3 F

## Oil-free pump with const. suct. rate robust, requ. little maintenance long service life, cont. operation



Current type: 3-phase AC  
Noise level (50 Hz): 67 dB  
Voltage (50 Hz): 190-254/330-440V AC3  
Voltage (60 Hz):  
190-290V/330-500V AC3  
with: Filter  
Suction rate (50 Hz): 40 m<sup>3</sup>/h  
Suction rate (60 Hz): 48 m<sup>3</sup>/h  
Vacuum (50Hz): -850 mbar  
Rated power (50 Hz): 1.25 kW  
Rated power (60 Hz): 1.5 kW  
Weight: 39.5 kg

### Design Data

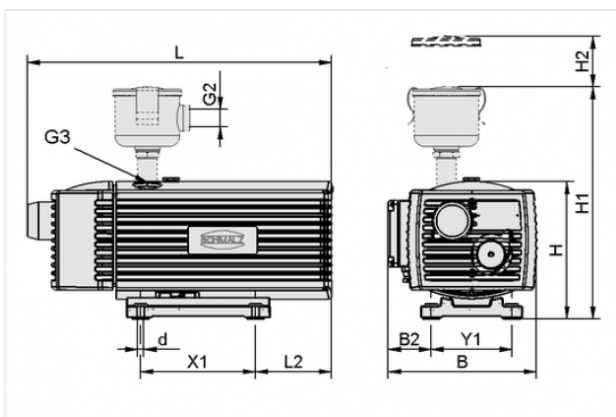

Attribute	Value
B	280 mm
B2	51 mm
d	7 mm
G2	G1-1/4"-F
G3	G3/4"-F
H	290 mm
H1	425 mm
H2	70 mm
L	572 mm
L2	131 mm

### Contact to Schmalz

J. Schmalz GmbH | Johannes-Schmalz-Straße, 72293 Glatten, Deutschland | +49 7443 2403-102 | [customercenter@schmalz.de](mailto:customercenter@schmalz.de)



Attribute	Value
X1	220 mm
Y1	199 mm

---

## Technical Data

Attribute	Value
Suction rate (50 Hz)	40 m <sup>3</sup> /h
Suction rate (60 Hz)	48 m <sup>3</sup> /h
Voltage (50 Hz)	190-254/330-440V AC3
Voltage (60 Hz)	190-290V/330-500V AC3
Rated power (50 Hz)	1.25 kW
Rated power (60 Hz)	1.5 kW
Noise level (50 Hz)	67 dB
Weight	39.5 kg
Protection	IP 54
Current type	AC3

---

## Accessories

### Contact to Schmalz



**FILT-EINS 3 98x70 PAP STF-1-1/4-IGN**

Part no. 10.07.01.00018

Filter insert (round)

Filter pore size: 3 µm

External diameter D: 98 mm

Length L: 70 mm

Filter material: Paper

for: Filters STF

Size: 1-1/4-IGN



**SBB-650x575x565-ST-VZ**

Part no. 10.04.04.00117

Silencer box for reduction of the noise level

Material: Steel

Surface: galvanised

Length L: 650 mm

Width B: 575 mm

Height H: 565 mm