

Vacuum pump

EVE-TR 100 AC3/S068 F IE2/UL/CSA

Part no.: 10.03.01.00259

<https://www.schmalz.com/10.03.01.00259>



Homepage > Vacuum Technology for Automation > Vacuum Components > Vacuum Generators > Vacuum Pumps > Dry-Running Vacuum Pumps
EVE-TR > EVE-TR 100 AC3/S068 F IE2/UL/CSA

Oil-free pump with constant suction rate, robust, requires little maintenance



Current type: 3-phase AC
Voltage (60 Hz): YY230/Y460V $\pm 10\%$
Voltage (60 Hz-opt):
YY208 $\pm 10\%$ (w/o IE2)
with: Filter
Suction rate (50 Hz): 98 m³/h
Suction rate (60 Hz): 112 m³/h
Vacuum (50Hz): -900 mbar
Permission: IE2/UL/CSA
Rated power (60 Hz): 3.6 kW
Weight: 102.5 kg

Design Data

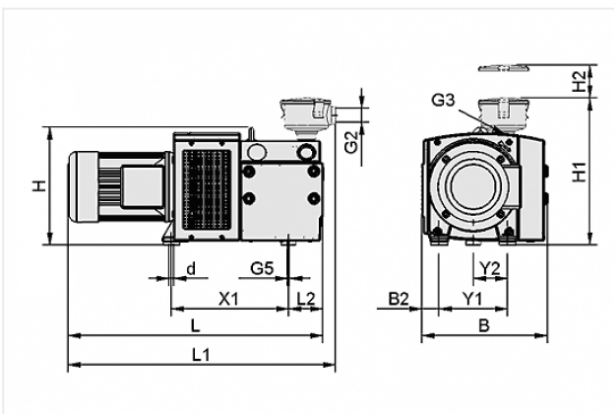

Attribute	Value
-----------	-------

B	470 mm
B2	110 mm
d	12 mm
G2	G1-1/4"-F
G3	G1-1/2"-F
G5	M8-F
H	336 mm
H1	466 mm
H2	75 mm
L	835 mm
L1	890 mm

Contact to Schmalz

J. Schmalz GmbH | Johannes-Schmalz-Straße, 72293 Glatten, Deutschland | +49 7443 2403-102 |
customercenter@schmalz.de



Attribute	Value
L2	140 mm
X1	398 mm
Y1	245 mm
Y2	122.5 mm

Technical Data

Attribute	Value
Suction rate (50 Hz)	98 m ³ /h
Suction rate (60 Hz)	112 m ³ /h
Voltage (60 Hz)	YY230/Y460V ±10%
Rated power (60 Hz)	3.6 kW
Current type	AC3
Weight	102.5 kg
Protection	IP 55

Contact to Schmalz