

Tooling-System- Schmalz-Ejektor

SEAC 10 RP R

<https://www.schmalz.com/10.02.02.03289>



Part no.: 10.02.02.03289

Homepage > Vacuum Technology for Automation > Vacuum Components > Vacuum Generators > Decentralized Ejectors > Ejectors with Blow Off
System SEAC RP > SEAC 10 RP R

Tooling-System-Schmalz-Ejektor



Nozzle size: 1,0 mm
with: pneum. air-saving regulation
Shape: Design right
Pressure range (operating pressure):
4.0 ... 6.0 bar

Design Data

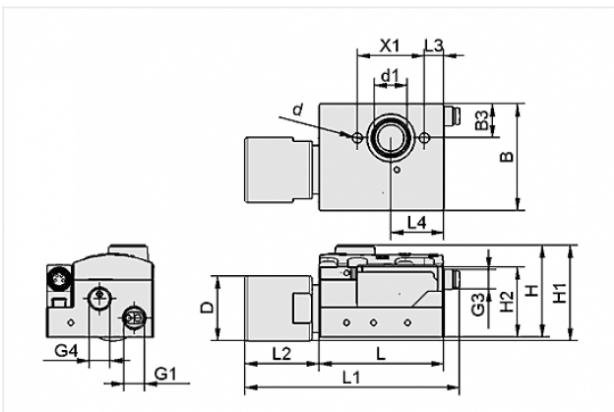

Attribute	Value
B	44.5 mm
B3	14.2 mm
d	4.3 mm
d1	13.8 mm
D	27 mm
G1	G1/8"-F
G4	G1/8"-F
H	38.3 mm
H1	39.8 mm
H2	29.3 mm
L	52 mm
L2	29.5 mm
L3	8 mm

Contact to Schmalz

J. Schmalz GmbH | Johannes-Schmalz-Straße, 72293 Glatten, Deutschland | +49 7443 2403-102 | customercenter@schmalz.de

Attribute	Value
L4	22 mm
X1	28 mm

Technical Data

Attribute	Value
Nozzle diameter	1 mm
Degree of evacuation	85 %
Suction rate (max)	36 l/min
Suction rate (max)	2.1 m ³ /h
Air consumption (during evac.)	65 l/min
Air consumption (during evac.)	3.9 m ³ /h
Air consumption (blow off) (max)	92 l/min
Pressure range (operating pressure)	4.0 ... 6.0 bar
Weight	180 g
Pressure range (operating pressure)	58.0 ... 87.0 psi
Suction rate (max)	1.271 cfm
Air consumption (during evac.)	2.295 cfm
Air consumption (blow off)	3.178 cfm
Vacuum (max)	25.1 inHg

Note:

- Air consumption: At optimal operating pressure (4,5 bar)