

Tooling-System-Schmalz-Ejektor

SEAC 10 VE-SH

<https://www.schmalz.com/10.02.02.03876>



Part no.: 10.02.02.03876

Homepage > Vacuum Technology for Automation > Vacuum Components > Vacuum Generators > Decentralized Ejectors > Ejectors with Active Blow Off SEAC > SEAC 10 VE-SH

Tooling-System-Schmalz-Ejektor



Nozzle size: 1,0 mm
with: Vac switch elec / Protect Hood
Pressure range (operating pressure):
4.0 ... 6.0 bar

Design Data

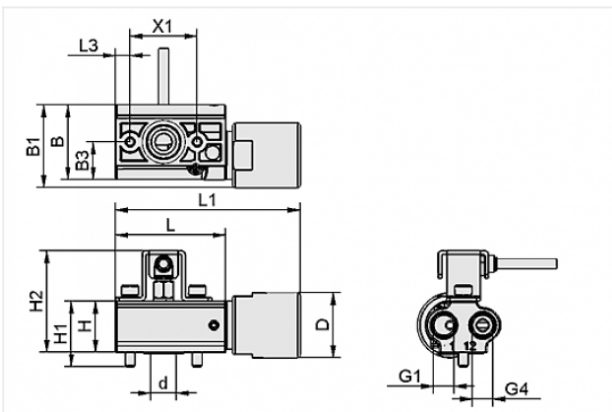

Attribute	Value
B	31 mm
B1	34.6 mm
B3	15.5 mm
d	7.5 mm
D	27 mm
G1	G1/8"-F
G4	G1/8"-F
H	21.5 mm
H1	27.5 mm
H2	42.5 mm
L	46 mm
L1	77 mm
L3	6 mm

Contact to Schmalz

J. Schmalz GmbH | Johannes-Schmalz-Straße, 72293 Glatten, Deutschland | +49 7443 2403-102 | customercenter@schmalz.de

Attribute	Value
X1	28 mm

Technical Data

Attribute	Value
Nozzle diameter	1 mm
Degree of evacuation	85 %
Suction rate (max)	35 l/min
Suction rate (max)	2.1 m ³ /h
Air consumption (during evac.)	52 l/min
Air consumption (during evac.)	3.12 m ³ /h
Air consumption (blow off) (max)	60 l/min
Air consumption (blow off)	3.6 m ³ /h
Pressure range (operating pressure)	4.0 ... 6.0 bar
Weight	157 g
Pressure range (operating pressure)	58.0 ... 87.0 psi
Suction rate (max)	1.235 cfm
Air consumption (during evac.)	1.836 cfm
Air consumption (blow off)	2.118 cfm
Vacuum (max)	25.1 inHg

Note:

- Air consumption: At optimal operating pressure (4,5 bar)