

Inline ejector

SLP 05 S01

<https://www.schmalz.com/10.02.01.00561>



Part no.: 10.02.01.00561

Homepage > Vacuum Technology for Automation > Vacuum Components > Vacuum Generators > Inline Ejectors > Inline Ejectors SLP > SLP 05 S01

Inline ejector for vacuum generation directly in the hose



Nozzle size: 0,5 mm
Degree of evacuation: 85 %
Connection: Hose D4(1)-D4(2)
Suction rate (max): 8 l/min
Air consumption (during evac.):
13 l/min
Pressure optimal: 4.5 bar

Design Data

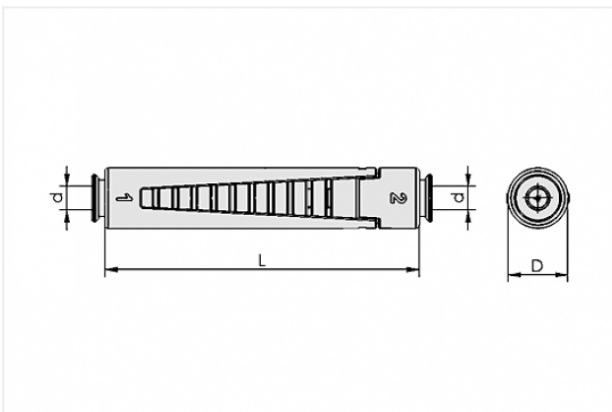

Attribute	Value
-----------	-------

d	4 mm
---	------

D	10 mm
---	-------

L	57 mm
---	-------

Technical Data

Attribute	Value
-----------	-------

Nozzle diameter	0.5 mm
-----------------	--------

Degree of evacuation	85 %
----------------------	------

Contact to Schmalz

J. Schmalz GmbH | Johannes-Schmalz-Straße, 72293 Glatten, Deutschland | +49 7443 2403-102 | customercenter@schmalz.de

Attribute	Value
Suction rate (max)	8 l/min
Suction rate (max)	0.5 m ³ /h
Air consumption (during evac.)	13 l/min
Air consumption (during evac.)	0.8 m ³ /h
Noise level (workp. gripped)	52 dB
Noise level (free)	60 dB
Pressure optimal	4.5 bar
Int. hose diameter (recom.) comp.-air	2 mm
Int. hose diameter (recom.) vacuum side	2 mm
Weight	5 g
Ambient temperature	0 ... 60 °C
Pressure optimal	65.2 psi
Suction rate (max)	0.282 cfm
Air consumption (during evac.)	0.459 cfm

Note:

- Air consumption: At optimal operating pressure
- Hose diameter: For max. length 2 m