

Insert disc for preventing film from being drawn in

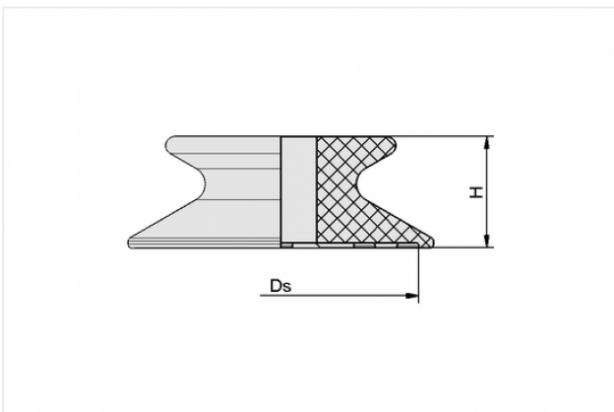

Size: 25
Material: Polyetheretherketon
Application: FG25/FGA25

Design Data



Attribute	Value
Ds	22.6 mm
H	10.1 mm

Technical Data

Attribute	Value
Application	FG25/FGA25
Material	Polyetheretherketon

Contact to Schmalz

Attribute	Value
Weight	2.6 g

Note:

- Suction capacity of min. 2 l/min is recommended. An experiment has to be carried out with the original workpiece and suction pads to define the required suction power for the application. Frictional force is reduced during vertical applications.
-
-