

# Bellows suction cup (round)

<https://www.schmalz.com/10.01.06.03631>



## SAB 80 NBR-60 M16-AG

Part no.: 10.01.06.03631

Homepage > Vacuum Technology for Automation > Vacuum Components > Vacuum Suction Cups > Suction Cups for Handling Sheet Metal >

Bellows Suction Cups SAB (1.5 Folds) > SAB 80 NBR-60 M16-AG

## Bellows suction cup (round) for very dynamic handling of smooth and oily workpieces



Size: 80  
Suction cup material:  
Nitrile rubber NBR  
Material hardness: 60 °Sh  
Vacuum connection: M16-M  
Nipple material: Aluminium  
Number of folds: 1.5

### Design Data

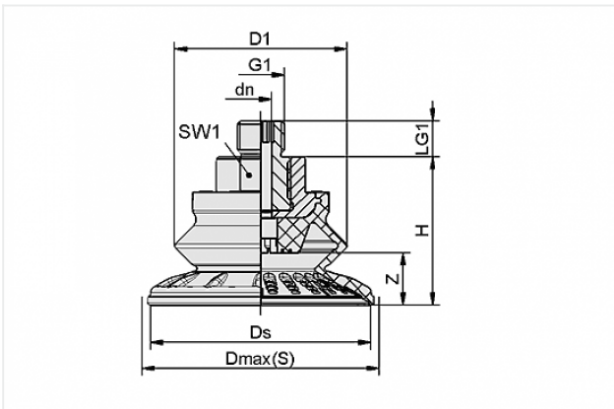

Attribute	Value
-----------	-------

dn	6 mm
D1	63.6 mm
Dmax(S)	89 mm
Ds	81.1 mm
G1	M16-M
H	49.9 mm
LG1	10 mm
SW1	22 mm
Z	22.1 mm

### Contact to Schmalz

J. Schmalz GmbH | Johannes-Schmalz-Straße, 72293 Glatten, Deutschland | +49 7443 2403-102 | [customercenter@schmalz.de](mailto:customercenter@schmalz.de)

## Technical Data

Attribute	Value
Suction force	135 N
Pull-off force	221 N
Lateral force	145 N
Lateral force (oily surface)	140 N
Volume	67.6 cm <sup>3</sup>
Curve radius (min) (convex)	75 mm
Internal hose diameter (recom.)	6 mm
Size	80
Suction cup material	Nitrile rubber NBR
Material hardness	60 °Sh
Weight	73.1 g
Number of folds	1.5
Product family	SAB

### Note:

- Suction force: The specified suction forces are theoretical values at a vacuum of -0.6 bar and with a smooth, dry workpiece surface - they do not include a safety factor
- Lateral force: The specified lateral forces are values measured at a vacuum of -0.6 bar with a dry or oily, smooth, flat workpiece surface. Depending on the workpiece surface and its quality, the actual values may deviate from these values
- Hose diameter: The recommended hose diameter refers to a hose length of approx. 2 m