

# Bellows suction cup (round)

<https://www.schmalz.com/10.01.06.00670>



## SAB 40 NBR-60 G1/4-IG

Part no.: 10.01.06.00670

Homepage > Vacuum Technology for Automation > Vacuum Components > Vacuum Suction Cups > Suction Cups for Handling Sheet Metal >

Bellows Suction Cups SAB (1.5 Folds) > SAB 40 NBR-60 G1/4-IG

## Bellows suction cup (round) for very dynamic handling of smooth and oily workpieces



Size: 40

Suction cup material:

Nitrile rubber NBR

Material hardness: 60 °Sh

Vacuum connection: G1/4-F

Nipple material: Aluminium

Number of folds: 1.5

### Design Data

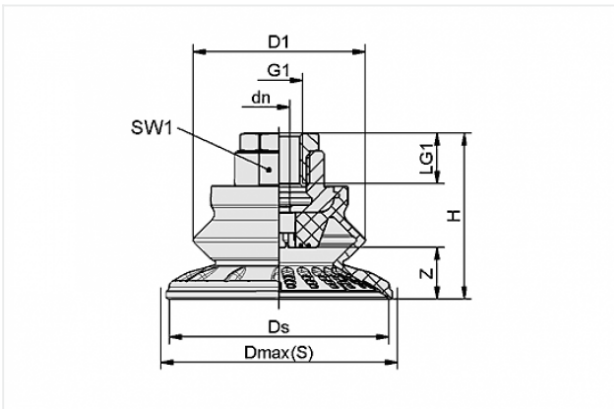

Attribute	Value
-----------	-------

dn	4 mm
----	------

D1	32 mm
----	-------

Dmax(S)	45 mm
---------	-------

Ds	40.1 mm
----	---------

G1	G1/4"-F
----	---------

H	28.8 mm
---	---------

LG1	12 mm
-----	-------

SW1	17 mm
-----	-------

Z	10 mm
---	-------

### Contact to Schmalz

J. Schmalz GmbH | Johannes-Schmalz-Straße, 72293 Glatten, Deutschland | +49 7443 2403-102 | [customercenter@schmalz.de](mailto:customercenter@schmalz.de)

## Technical Data

Attribute	Value
Suction force	38 N
Pull-off force	59 N
Lateral force	36 N
Lateral force (oily surface)	33 N
Volume	8.68 cm <sup>3</sup>
Curve radius (min) (convex)	40 mm
Internal hose diameter (recom.)	4 mm
Size	40
Suction cup material	Nitrile rubber NBR
Material hardness	60 °Sh
Weight	14.3 g
Number of folds	1.5
Product family	SAB

### Note:

- Suction force: The specified suction forces are theoretical values at a vacuum of -0.6 bar and with a smooth, dry workpiece surface - they do not include a safety factor
- Lateral force: The specified lateral forces are values measured at a vacuum of -0.6 bar with a dry or oily, smooth, flat workpiece surface. Depending on the workpiece surface and its quality, the actual values may deviate from these values
- Hose diameter: The recommended hose diameter refers to a hose length of approx. 2 m