

Bellows suction cup (round)

<https://www.schmalz.com/10.01.06.01203>



SAB 30 NBR-60 RA

Part no.: 10.01.06.01203

Homepage > Vacuum Technology for Automation > Vacuum Components > Vacuum Suction Cups > Suction Cups for Handling Sheet Metal >

Bellows Suction Cups SAB (1.5 Folds) > SAB 30 NBR-60 RA

Bellows suction cup (round) for very dynamic handling of smooth and oily workpieces



Size: 30

Suction cup material:

Nitrile rubber NBR

Material hardness: 60 °Sh

Vacuum connection:

Rectangular adapter

Nipple material: Aluminium

Number of folds: 1.5

Design Data

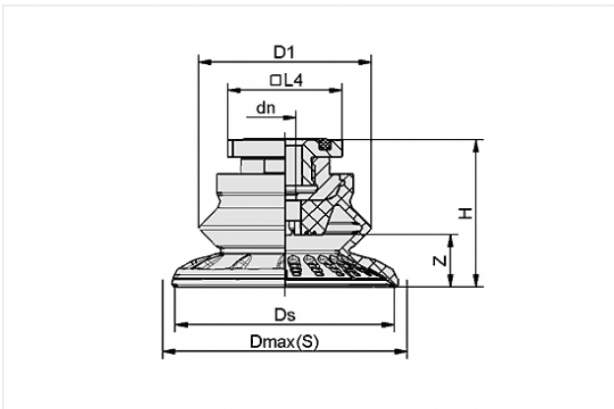

Attribute	Value
-----------	-------

dn	4 mm
----	------

D1	32 mm
----	-------

Dmax(S)	34 mm
---------	-------

Ds	30.6 mm
----	---------

H	31.2 mm
---	---------

L4	31.8 mm
----	---------

Z	9 mm
---	------

Technical Data

Contact to Schmalz

J. Schmalz GmbH | Johannes-Schmalz-Straße, 72293 Glatten, Deutschland | +49 7443 2403-102 | customercenter@schmalz.de

Attribute	Value
Suction force	22 N
Pull-off force	33 N
Lateral force	30 N
Lateral force (oily surface)	13 N
Volume	5.73 cm ³
Curve radius (min) (convex)	40 mm
Internal hose diameter (recom.)	4 mm
Size	30
Suction cup material	Nitrile rubber NBR
Material hardness	60 °Sh
Weight	26.9 g
Number of folds	1.5
Product family	SAB

Note:

- Suction force: The specified suction forces are theoretical values at a vacuum of -0.6 bar and with a smooth, dry workpiece surface - they do not include a safety factor
- Lateral force: The specified lateral forces are values measured at a vacuum of -0.6 bar with a dry or oily, smooth, flat workpiece surface. Depending on the workpiece surface and its quality, the actual values may deviate from these values
- Hose diameter: The recommended hose diameter refers to a hose length of approx. 2 m