

# Bellows suction cup (round)

<https://www.schmalz.com/10.01.06.01650>



## SAB 22 NBR-60 G3/8-IG

Part no.: 10.01.06.01650

Homepage > Vacuum Technology for Automation > Vacuum Components > Vacuum Suction Cups > Suction Cups for Handling Sheet Metal >

Bellows Suction Cups SAB (1.5 Folds) > SAB 22 NBR-60 G3/8-IG

## Bellows suction cup (round) for very dynamic handling of smooth and oily workpieces



Size: 22  
Suction cup material:  
Nitrile rubber NBR  
Material hardness: 60 °Sh  
Vacuum connection: G3/8-F  
Nipple material: Brass, nickel-plated  
Number of folds: 1.5

### Design Data

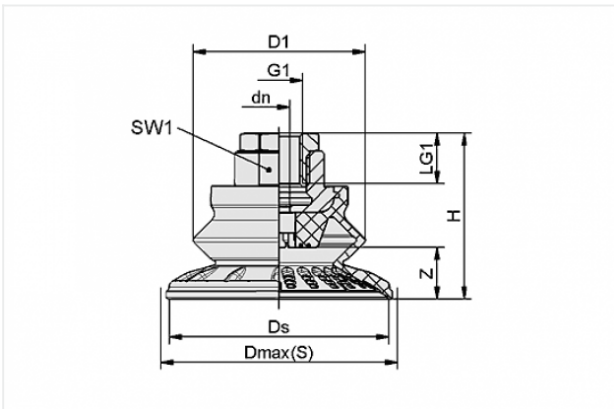

Attribute	Value
-----------	-------

dn	3.5 mm
----	--------

D1	22 mm
----	-------

Dmax(S)	24 mm
---------	-------

Ds	20.6 mm
----	---------

G1	G3/8"-F
----	---------

H	41 mm
---	-------

LG1	9.5 mm
-----	--------

SW1	22 mm
-----	-------

Z	5.8 mm
---	--------

### Contact to Schmalz

J. Schmalz GmbH | Johannes-Schmalz-Straße, 72293 Glatten, Deutschland | +49 7443 2403-102 | [customercenter@schmalz.de](mailto:customercenter@schmalz.de)

## Technical Data

Attribute	Value
Suction force	16 N
Pull-off force	24 N
Lateral force	18 N
Lateral force (oily surface)	6 N
Volume	2.48 cm <sup>3</sup>
Curve radius (min) (convex)	20 mm
Internal hose diameter (recom.)	4 mm
Size	22
Suction cup material	Nitrile rubber NBR
Material hardness	60 °Sh
Weight	9 g
Number of folds	1.5
Product family	SAB

### Note:

- Suction force: The specified suction forces are theoretical values at a vacuum of -0.6 bar and with a smooth, dry workpiece surface - they do not include a safety factor
- Lateral force: The specified lateral forces are values measured at a vacuum of -0.6 bar with a dry or oily, smooth, flat workpiece surface. Depending on the workpiece surface and its quality, the actual values may deviate from these values
- Hose diameter: The recommended hose diameter refers to a hose length of approx. 2 m