

Bellows suction cup (round)

<https://www.schmalz.com/10.01.06.01653>



SAB 22 NBR-60 G1/4-AG

Part no.: 10.01.06.01653

Homepage > Vacuum Technology for Automation > Vacuum Components > Vacuum Suction Cups > Suction Cups for Handling Sheet Metal >

Bellows Suction Cups SAB (1.5 Folds) > SAB 22 NBR-60 G1/4-AG

Bellows suction cup (round) for very dynamic handling of smooth and oily workpieces



Size: 22
Suction cup material:
Nitrile rubber NBR
Material hardness: 60 °Sh
Vacuum connection: G1/4-M
Nipple material: Aluminium
Number of folds: 1.5

Design Data

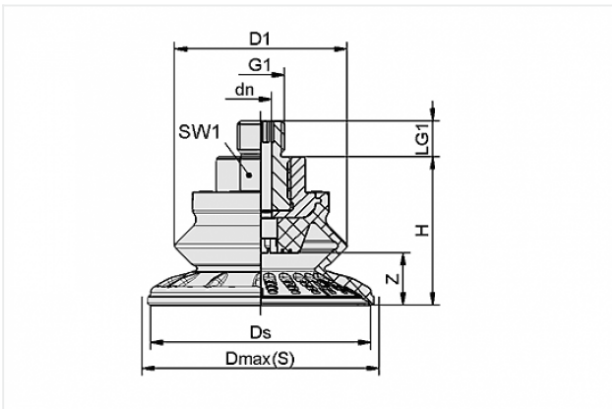

Attribute	Value
dn	3.5 mm
D1	22 mm
Dmax(S)	24 mm
Ds	20.6 mm
G1	G1/4"-M
H	25 mm
LG1	10 mm
SW1	16 mm
Z	5.8 mm

Contact to Schmalz

J. Schmalz GmbH | Johannes-Schmalz-Straße, 72293 Glatten, Deutschland | +49 7443 2403-102 | customercenter@schmalz.de

Technical Data

Attribute	Value
Suction force	16 N
Pull-off force	24 N
Lateral force	18 N
Lateral force (oily surface)	6 N
Volume	2.48 cm ³
Curve radius (min) (convex)	20 mm
Internal hose diameter (recom.)	4 mm
Size	22
Suction cup material	Nitrile rubber NBR
Material hardness	60 °Sh
Weight	7 g
Number of folds	1.5
Product family	SAB

Note:

- Suction force: The specified suction forces are theoretical values at a vacuum of -0.6 bar and with a smooth, dry workpiece surface - they do not include a safety factor
- Lateral force: The specified lateral forces are values measured at a vacuum of -0.6 bar with a dry or oily, smooth, flat workpiece surface. Depending on the workpiece surface and its quality, the actual values may deviate from these values
- Hose diameter: The recommended hose diameter refers to a hose length of approx. 2 m