

# Bellows suction cup (oval)

<https://www.schmalz.com/10.01.06.03206>



## SAOB 110x55 HT1-60 G1/4-AG

Part no.: 10.01.06.03206

Homepage > Vacuum Technology for Automation > Vacuum Components > Vacuum Suction Cups > Bellows Suction Cups (Oval) > Bellows Suction Cups SAOB HT1 (Oval, 1.5 Folds) > SAOB 110x55 HT1-60 G1/4-AG

### Bellows suction cup (oval) for high dynamic on curved, oily surfaced workpieces



Dimensions (LxB): 110 x 55 mm

Suction cup material:

High temp material HT1

Material hardness: 60 °Sh

Nipple material: Aluminium

Vacuum connection: G1/4-M

Number of folds: 1.5

### Design Data

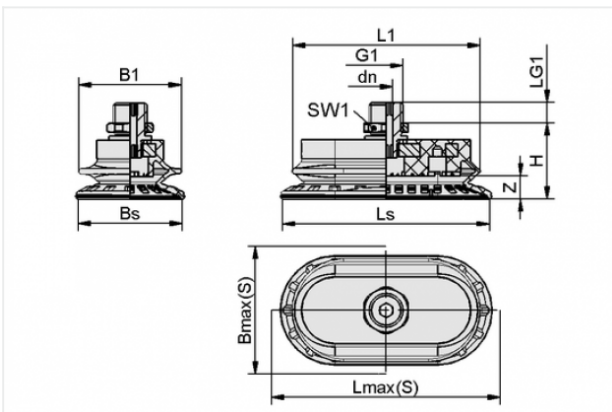

Attribute	Value
-----------	-------

B1	53 mm
----	-------

Bmax(S)	59 mm
---------	-------

Bs	55.1 mm
----	---------

dn	6 mm
----	------

G1	G1/4"-M
----	---------

H	35.5 mm
---	---------

L1	98.8 mm
----	---------

LG1	8 mm
-----	------

Lmax(S)	114 mm
---------	--------

Ls	110.1 mm
----	----------

SW1	17 mm
-----	-------

Z	12 mm
---	-------

### Contact to Schmalz

J. Schmalz GmbH | Johannes-Schmalz-Straße, 72293 Glatten, Deutschland | +49 7443 2403-102 | [customercenter@schmalz.de](mailto:customercenter@schmalz.de)

## Technical Data

Attribute	Value
Suction force	110 N
Pull-off force	233.5 N
Lateral force	299.2 N
Lateral force (oily surface)	123.6 N
Volume	53.1 cm <sup>3</sup>
Curve radius (min) (convex)	50 mm
Internal hose diameter (recom.)	6 mm
Dimensions (LxB)	110 x 55 mm
Number of folds	1.5
Suction cup material	High temp material HT1
Material hardness	60 °Sh
Weight	79.7 g
Product family	SAOB

### Note:

- Suction force: The specified suction forces are theoretical values at a vacuum of -0.6 bar and with a smooth, dry workpiece surface - they do not include a safety factor
- Lateral force: The specified lateral forces are values measured at a vacuum of -0.6 bar with a dry or oily, smooth, flat workpiece surface. Depending on the workpiece surface and its quality, the actual values may deviate from these values
- Hose diameter: The recommended hose diameter refers to a hose length of approx. 2 m