

# Bellows suction cup (oval)

<https://www.schmalz.com/10.01.06.03201>



## SAOB 60x30 HT1-60 G3/8-AG

Part no.: 10.01.06.03201

Homepage > Vacuum Technology for Automation > Vacuum Components > Vacuum Suction Cups > Bellows Suction Cups (Oval) > Bellows Suction Cups SAOB HT1 (Oval, 1.5 Folds) > SAOB 60x30 HT1-60 G3/8-AG

### Bellows suction cup (oval) for high dynamic on curved, oily surfaced workpieces



Dimensions (LxB): 60 x 30 mm

Suction cup material:

High temp material HT1

Material hardness: 60 °Sh

Nipple material: Aluminium

Vacuum connection: G3/8-M

Number of folds: 1.5

### Design Data

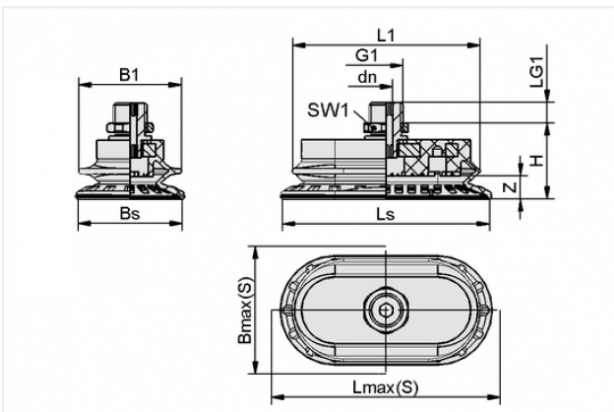

Attribute	Value
-----------	-------

B1	31 mm
----	-------

Bmax(S)	33 mm
---------	-------

Bs	30.6 mm
----	---------

dn	5.2 mm
----	--------

G1	G3/8"-M
----	---------

H	27.5 mm
---	---------

L1	55.7 mm
----	---------

LG1	7.4 mm
-----	--------

Lmax(S)	63 mm
---------	-------

Ls	60.6 mm
----	---------

SW1	22 mm
-----	-------

Z	7 mm
---	------

### Contact to Schmalz

J. Schmalz GmbH | Johannes-Schmalz-Straße, 72293 Glatten, Deutschland | +49 7443 2403-102 | [customercenter@schmalz.de](mailto:customercenter@schmalz.de)

## Technical Data

Attribute	Value
Suction force	38 N
Pull-off force	69.5 N
Lateral force	80.1 N
Lateral force (oily surface)	40.5 N
Volume	10.5 cm <sup>3</sup>
Curve radius (min) (convex)	18 mm
Internal hose diameter (recom.)	4 mm
Dimensions (LxB)	60 x 30 mm
Number of folds	1.5
Suction cup material	High temp material HT1
Material hardness	60 °Sh
Weight	30 g
Product family	SAOB

### Note:

- Suction force: The specified suction forces are theoretical values at a vacuum of -0.6 bar and with a smooth, dry workpiece surface - they do not include a safety factor
- Lateral force: The specified lateral forces are values measured at a vacuum of -0.6 bar with a dry or oily, smooth, flat workpiece surface. Depending on the workpiece surface and its quality, the actual values may deviate from these values
- Hose diameter: The recommended hose diameter refers to a hose length of approx. 2 m