

TORQUE HINGE (CONCEALED)

SUS HG-TUWA



Features

- High torque and wide opening angle (130°) type of HG-TU.
- Installation on the back side of the door for clean appearance.
- Can be used horizontally or vertically.

Remarks

- High torque and wide opening angle (130°) type of HG-TU.
- Installation on the inner side of the door for a clean appearance.
- Can be used horizontally or vertically.
- When installing, ensure that both hinge shafts are aligned.

Selection Tool
Sasuga-kun
 Applicable Products
 Used for Product Selection & Simulation.
 Available on Web!

Application Example

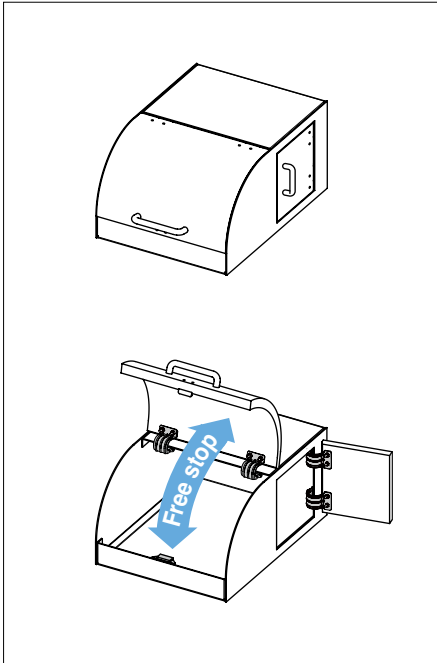

Dimensions

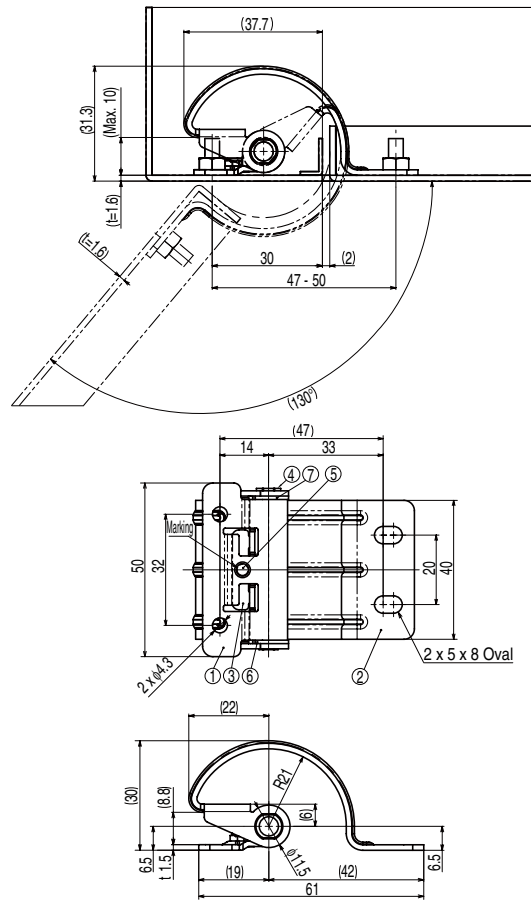

Installation

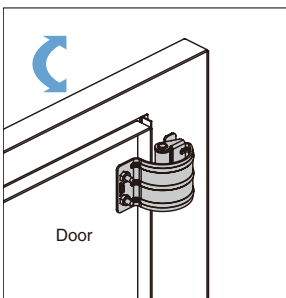

No.	Part Name	Material	Finish/Colour
①	Body	Stainless Steel (SUS304)	Barrel Polished
②	Base		
③	Press Washer	Stainless Steel (SUS303)	-
④	Shaft		
⑤	Pin	Stainless Steel	
⑥	Fixing Tube L	POM	Black
⑦	Fixing Tube R		

CAD	Item Code	Item Name	Torque N-m/pc	Torque kgf-cm/pc	Weight (g)	Box (pcs)	Carton (pcs)
PCSD	170-034-313	HG-TUWA07	0.7 ^{+40%} / _{-20%}	7.1 ^{+40%} / _{-20%}	88	20	100
PCSD	170-034-314	HG-TUWA15	1.5 ^{+40%} / _{-20%}	15.3 ^{+40%} / _{-20%}		20	100