

EXTENSION HANGER

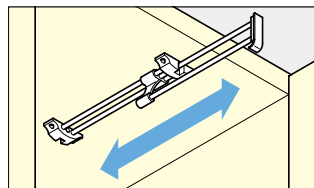

WH

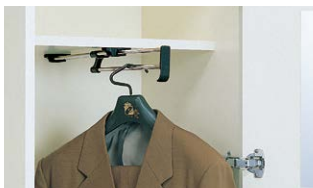
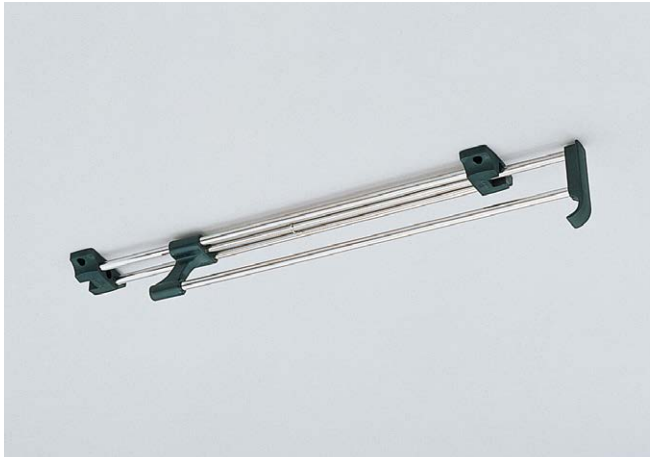

Features

Space-saving, undermount design for narrow spaces.

Parts Included

Pan head tapping screw 3.5x20

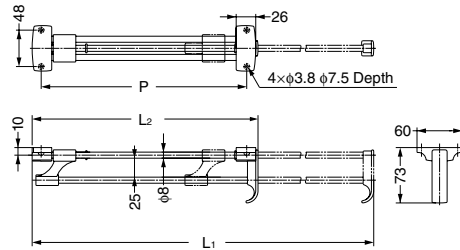

Part Name	Material	Finish/Colour
Hanger Rod	Steel	Nickel
Retainer Guide	Polyamide (PA)	Black

Item Code	Item Name	L ₁	L ₂	P	Load Capacity		Weight	Box	Carton
110-020-131	WH-300	498	300	273	58.8 N	6 kgf	485 g	5 pcs	30 pcs
110-020-132	WH-350	570	350	323	49 N	5 kgf	560 g	5 pcs	30 pcs
110-020-133	WH-400	628	400	373	49 N	5 kgf	630 g	5 pcs	30 pcs
110-020-134	WH-450	698	450	423	39.2 N	4 kgf	715 g	5 pcs	30 pcs

EXTENSION HANGER



AS

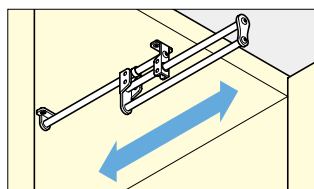

Features

Space-saving, undermount design for narrow spaces.

Parts Included

Raised countersunk head wood screw 3.5x25 (SUS)

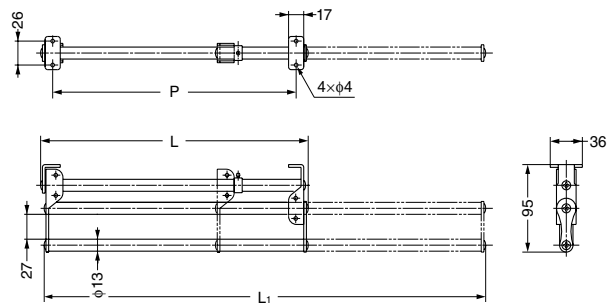

Item Code	Item Name	Material	Finish	L ₁	L	P	Load Capacity		Weight	Box	Carton
110-020-138	AS-300	Stainless Steel (SUS430)	Satin	495	300	273	49 N	5 kgf	395 g	5 pcs	50 pcs
110-020-139	AS-330	Stainless Steel (SUS430)	Satin	545	330	303	49 N	5 kgf	420 g	5 pcs	50 pcs
110-020-140	AS-360	Stainless Steel (SUS430)	Satin	598	360	333	49 N	5 kgf	405 g	5 pcs	50 pcs
110-020-141	AS-400	Stainless Steel (SUS430)	Satin	665	400	373	49 N	5 kgf	440 g	5 pcs	50 pcs