

LAMP® FD80-H SLIDING DOOR SYSTEM Installation Manual (Recessed Roller, Standard Sliding)

Part No.FD80HHP

Thank you for selecting our product. Before starting installation, please read this manual thoroughly to ensure correct installation. Please keep this manual at hand for future reference.

ABOUT THE PRODUCT

- This product is a parts set for heavy duty sliding door system for indoor use.

SPECIFICATIONS

Door height	Max. 2500 mm	2501 - 2700 mm
Door width	784 - 1500 mm	850 - 1500 mm
Min.Door thickness	34 mm	
Max.Door weight	80 kg	
Height adjustable range	1 mm upward, 4 mm downward	

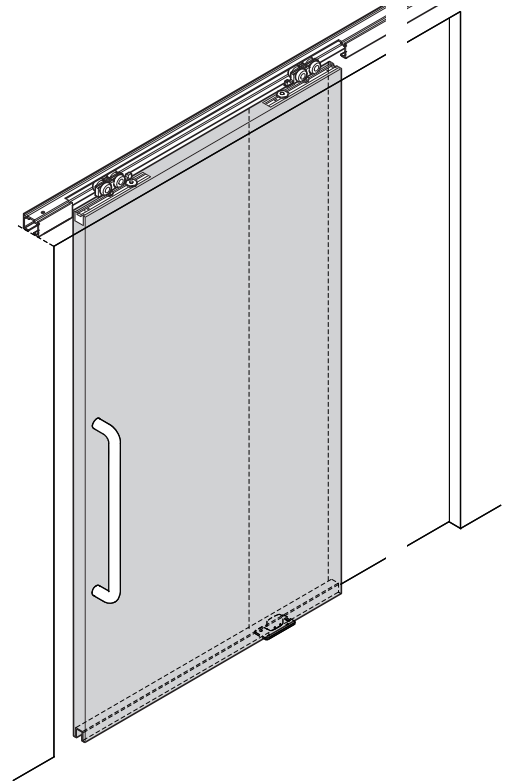

FOR YOUR SAFE WORK AND CORRECT INSTALLATION

Meaning of symbols

 Warning Caution	 Prohibited	 Required
---	---	---









WARNING: If not followed, death or serious injury may result.

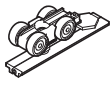
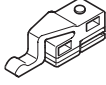
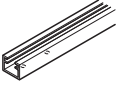

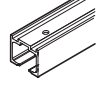
- ❗ This (sliding door system) should be installed by a qualified person. If the system is not installed correctly, the door will not operate smoothly, and may cause injury.
- ❗ It is necessary to manufacture the frame with sufficient strength so that it endures the weight of the door and any impact upon opening/closing the door. Only use designated screws and ensure that they are fastened firmly. A frame with poor strength or loose screws might result in the door falling and causing injury.
- ⊘ Do not try to use this product for anything other than its original purpose. Do not use any part for applications outside of its specification.
- ⊘ Do not disassemble nor modify any parts other than those described in this document.

Caution: If not followed, injury or damage may result.

- ❗ Make sure to follow the designated dimensions, specifications, and horizontal/vertical angles. Make sure that the frame is not warped, since it may affect the movement of the door.
- ❗ If cutting any parts, make sure to remove any burrs before installation. Also check the upper track for any left-over burrs or scraps and remove these.
- ❗ This product is a part for architectural fittings. After installation, make sure to test the finished product thoroughly to ensure that it is well-functioning and safe.
- ❗ Make sure to check the screws for slack at regular intervals (one month from first usage, half a year and then one time every year is recommended).

COMPONENT PARTS

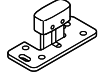
No.	①	②	③	④	⑤	⑥	⑦	⑧
Name	Recessed roller	End stopper	Hanging bracket	End cap	Floor guide S	Upper track	Door guide track	Spanner
Item No.	FD80-WRH	FD80-HTST	FD70B-HB160	FD70B-EC-BL	FD50-BG18	FD80-TRM series	FD30-HBRT1500SIL	FD80-HHSP
Item	 Accessory: Hexagon socket screw key 3 mm		160mm  Accessory screw: Pan head tapping screw 5x40 4 pcs	Black 	 Accessory screw: Bind head tapping screw 4x16 5 pcs	(Various sizes) Hole pitch :250 mm Pitch end :30 mm  Accessory screw: Pan head tapping screw 5x40	1500 mm Hole pitch :250 mm Pitch end :30mm 	 Nominal designation 13,22
Single sliding	 2 pcs	2 pcs	2 pcs	2 pcs	1 pc	1 pc	1 pc	1 pc
Double sliding	 4 pcs	4 pcs	4 pcs	4 pcs	2 pcs	2 pcs	2 pcs	1 pc
In line sliding	 4 pcs	4 pcs	4 pcs	4 pcs	2 pcs	1 pc	2 pcs	1 pc

OPTIONAL PARTS	No.	⑨	⑩
	Name	Floor guide L	End cap
	Item No.	FD50-BG32	FD70B-EC-BL
Item	Needed when vertical frame is not use.  Accessory screw: Bind head tapping screw 4x16 5 pcs	This is used when larger space below the door is required. 	

INSTALLATION DRAWING (EXAMPLE)

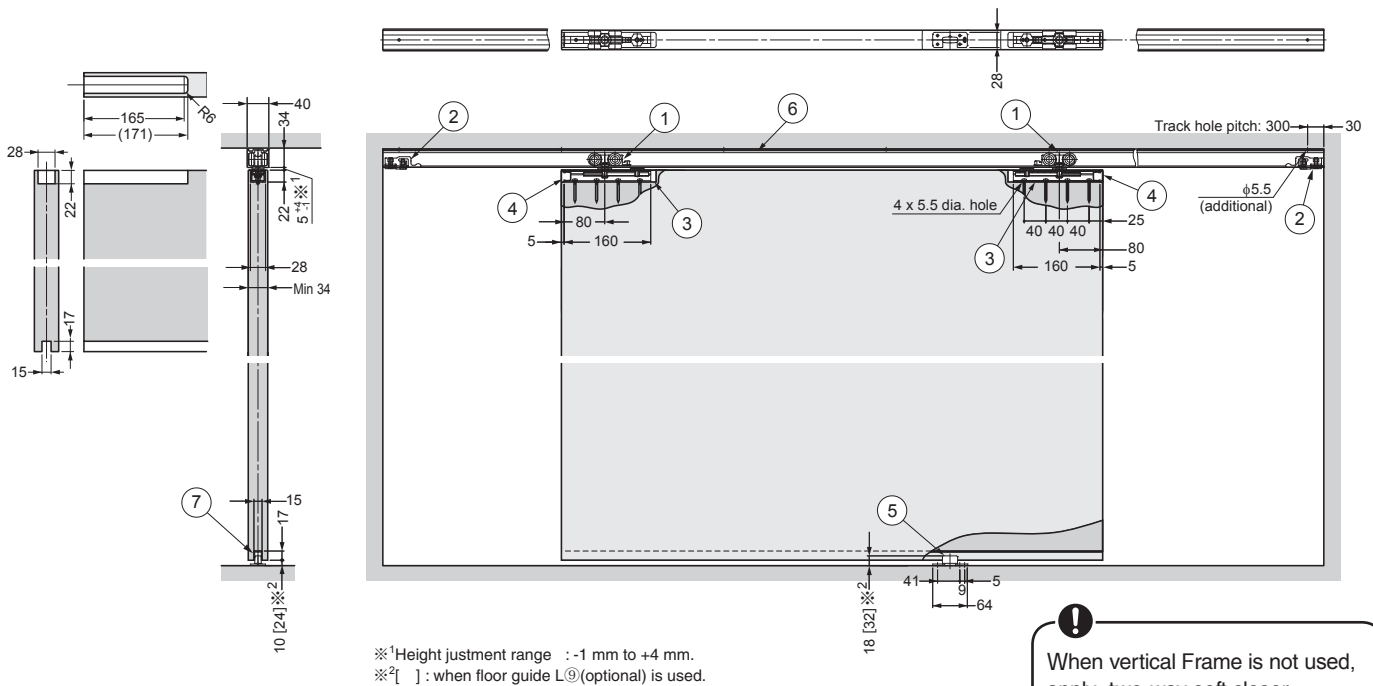

INSTALLATION PROCEDURE

This describes installation of a single sliding door.

1 PREPARATION AND ASSEMBLY

1. Cutting and Drilling Holes on Upper Track

- ① When cutting, reinforce the track to prevent deformation at the cut section.
- ① Remove any dirt or aluminum chips from the track.

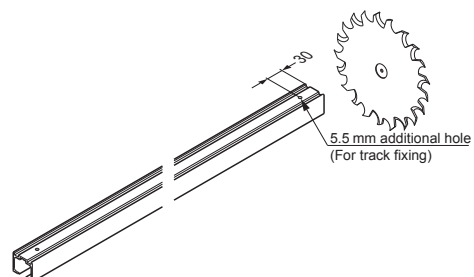

2. Assembling of Hanging Bracket

Fixing position

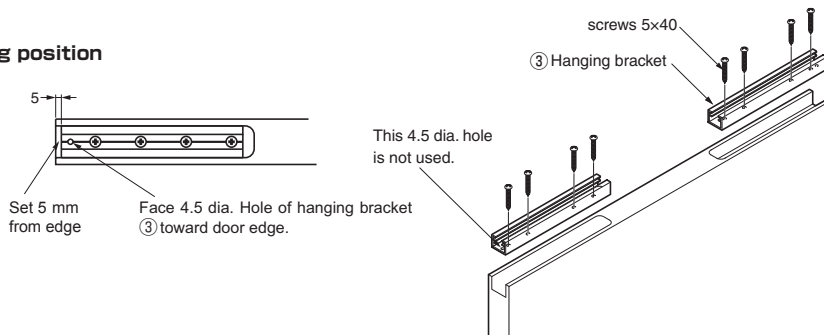

3. Installing Door Guide Track

- (1) Cut the track to the same length as the door width.
- ① When cutting, reinforce the track to prevent deformation at the cut section.
- (2) Fasten the track with countersunk head tapping screws 4 × 16 (not provided)

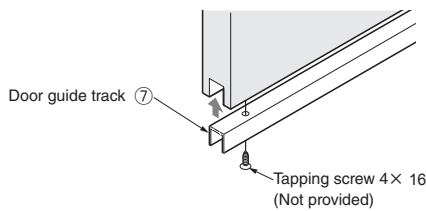

4. Inserting Parts into Upper Track

Assemble the parts in order from ① to ④ with care of direction.

- ① Fasten end stoppers temporarily to prevent the inserted parts from falling.

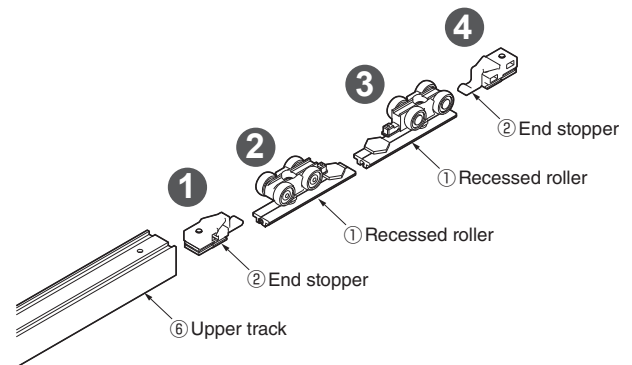

5. Installation of Track

- ① Remove any dirt or aluminum chips from the track.

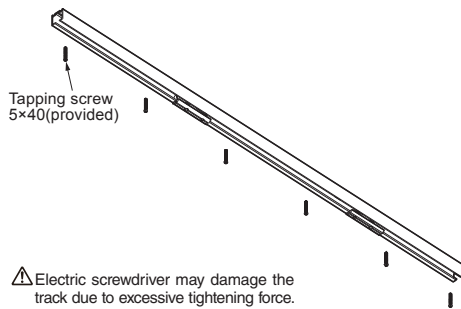

⚠ Electric screwdriver may damage the track due to excessive tightening force. Manual driver is recommended.

6. Mounting Floor Guide

- (1) Position floor guide just below the center of upper track.
- (2) Position the floor guide so that the floor guide stays under the door when it is opened or closed.

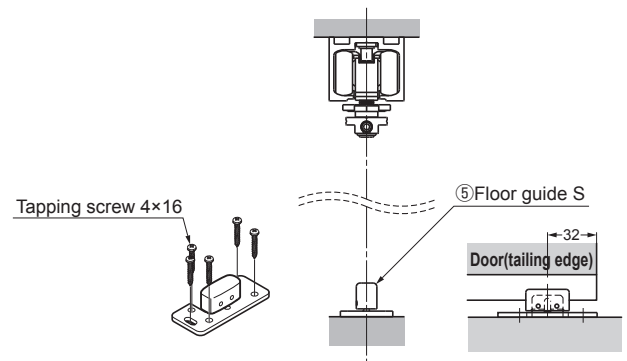

2 HANGING THE DOOR AND ADJUSTMENT

1. Hanging (Bottom part)

Put a 10 mm support under the door. While holding the door, insert the floor guide into the groove under the door.

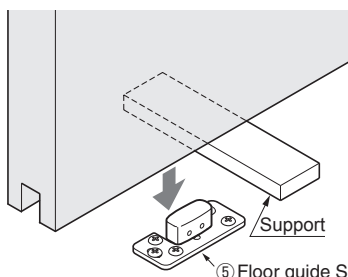

2. Hanging (Top part)

Insert the recessed roller into the hanging bracket in the door. Position upper roller hanger bolt to 80mm from door edge (41mm to fix plate edge). Tighten fix bolt with spanner (22 mm).

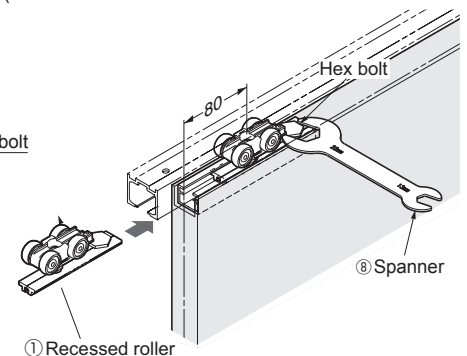
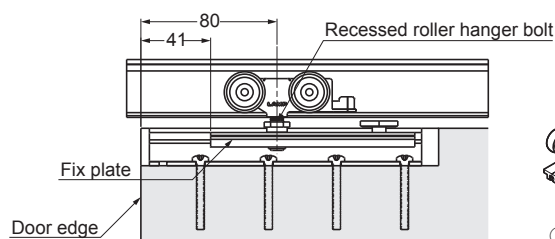

3. Fixing End Stopper and Adjustment

- (1) Remove the 10 mm support under the door.
- (2) Fix end stopper with the door fully closed.
Set the position of end stopper such that roller in the track contacts with end stopper, tighten position-set screw with Phillips head driver #2.
- (3) Using Phillips head driver #2, adjust door catch force by the adjust screw.
- (4) Attach the other stopper and adjust it at opposite end in similar manner.

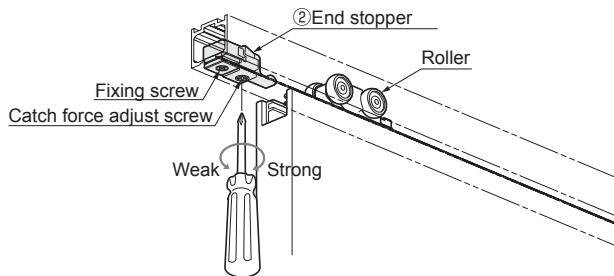

4. Adjustment of Door Height

- Adjust the door parallel to the upper track with 6-11 mm of clearance between the door and floor.
- Then, tighten upper roller fixing screw with provided spanner.
- Fix the position with provided hex key.

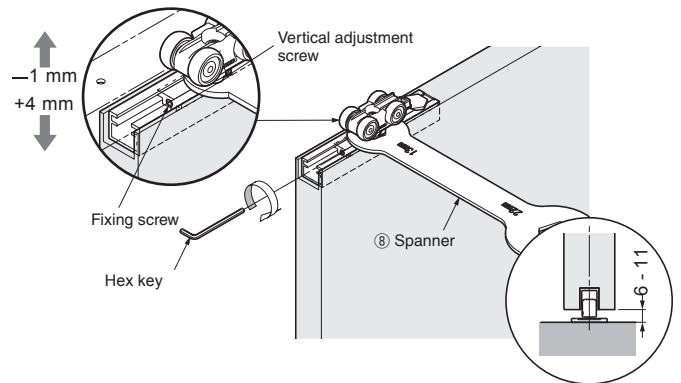

5. Assembling End Cap

Insert end cap into hanging bracket, as shown in figure below.

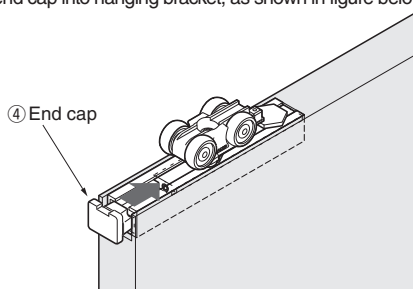

■ HOW TO REMOVE DOOR

- (1) Put a support under the door.
- (2) Remove End cap. (See 2-5.)
- (3) Loosen the Fix bolt with provided spanner.

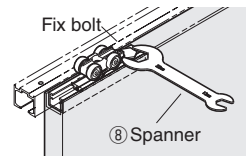

- (4) Pull out the recessed roller from the Hanging bracket.

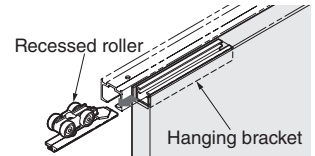

- (5) Remove the door from the floor guide.

Final verification Verify that all screws are securely tightened, and verify that all screws have been used.

Periodical Inspection

- Clean inside of rail.
- Check upper space and lower space of the door. If necessary, correct the space.

TROUBLESHOOTING

Trouble	Check Point	Solution
Abnormal noise during operation	Check if door bottom contacts the floor.	Verify that the track fixing screws are not loosened. Adjust the door height 6-11 mm between the door bottom and floor.
	Check inside of upper track for existence of foreign matter such as aluminum dust.	Remove dust or foreign matter.
	Check track rollers for existence of dust or aluminum powder.	Remove the track and pull out the roller. Then, clean the roller.
	Check for loose screws retaining the upper track.	Tighten the screw.
Heavy door operation	Check if door bottom contacts the floor.	Verify that the track fixing screws are not loosened. Adjust the door height 6-11 mm between the door bottom and floor.
Door does not move.	Check track retaining screws for looseness.	Tighten the screw.
Door starts to move.	Check if the upper track is set horizontally.	Using a level gauge, reset upper track horizontally.

SUGATSUNE KOGYO CO.,LTD
Tokyo, JAPAN
Phone: +81 (0)3 3866 2260 E-mail:export@sugatsune.co.jp

SUGATSUNE KOGYO (UK) LTD
Reading, UK
Phone: +44 118 9272 955 E-mail:sales@sugatsune.co.uk

SUGATSUNE EUROPE GmbH
Düsseldorf, GERMANY
Phone: +49 211 53812900 E-mail:sales@sugatsune.eu

SUGATSUNE SHANGHAI Co., LTD
Shanghai, CHINA
Phone: +86 21 3632 1858 E-mail:lamp@sugatsune.com.cn

Guangzhou, CHINA
Phone: +86 20 6639 3552 E-mail:lamp@sugatsune.com.cn

SUGATSUNE KOGYO INDIA PRIVATE LIMITED
Mumbai, INDIA
Phone: +91 22 28314490/91 E-mail:sales@sugatsune.in

SUGATSUNE AMERICA, INC
California, USA
Phone: +1 310 329 6373 E-mail:sales@sugatsune.com

Chicago, USA
Phone: +1 312 461 1081 E-mail:chicagoshowroom@sugatsune.com.

SUGATSUNE CANADA, INC.
Phone: +1 514 312 5267 E-mail:support@sugatsune.ca

ISO9001(Japan Offices and Sugatsune America) and ISO14001(Chiba Production division and Logistics center), certified.

2018.12 0562-4