

# TOP MOUNTED SLIDING DOOR (TWO-WAY SOFT CLOSE TYPE/OUTSET/RECESSED UPPER ROLLER) INSTRUCTION **FD35EV**

This two-way soft closing sliding door operates smoothly and requires little strength to operate, making it ideal for retail shops and other public areas as well. Can be retrofitted to the top wall of entrances.

Passed 300,000 cycles of in-house opening and closing testing

Features	Door Size (per door)	Adjustment
<p><b>Two-Way Soft Close</b> (both directions)</p> <p>With Sequential Double Damper (2 stages)</p>	<p>30 - 36 mm</p> <p>Maximum 2400 mm</p> <p>590 - 1200 mm</p> <p>Weight: Maximum 35 kg</p> <p>10 kg or more recommended</p>	<p>-3 mm +4 mm</p> <p>±2 mm</p>

**2-Stage**

Soft closing starts at approx. 100 mm for reliable operation

Soft opening With Sequential Double Damper in two stages enables **less force** to be used when opening too (compared to FD30).

**Remarks**

- Be sure to read the precautions for this product.
- Be sure to read the installation.

**1-Stage**

Damper in the opening direction slows down

from around 50 mm on trailing edge side.

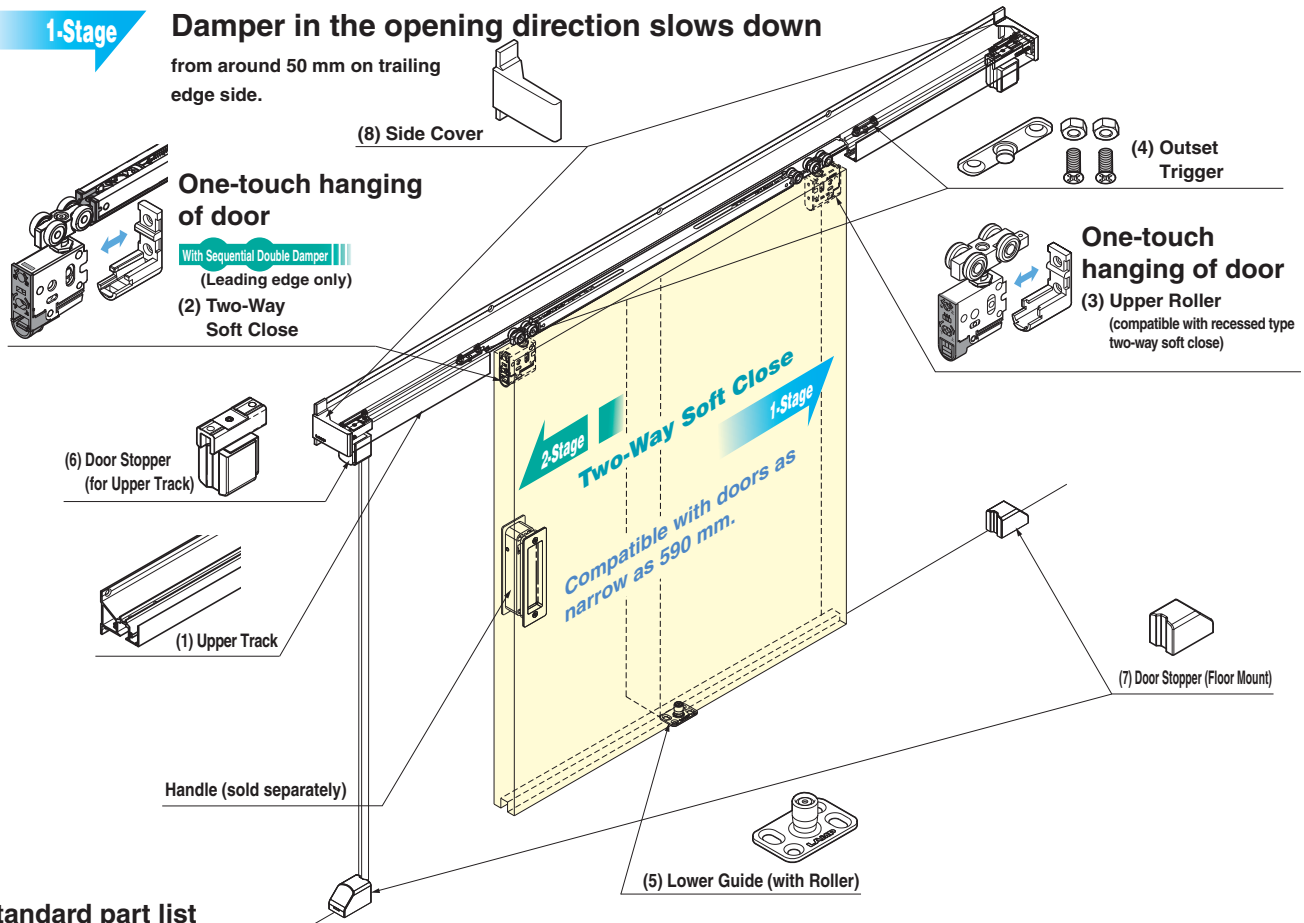

**Standard part list**

See "Type of Outset Upper Track" for details on the type of upper track used for (1).

Parts	Necessary Parts							Necessary Parts (Select Colour)	Recommended Options
	(1) Upper Track	(2) Two-Way Soft Close*1	(3) Upper Roller (compatible with recessed type two-way soft close)	(4) Outset Trigger 2 pcs	(5) Lower Guide (with Roller)	(6) Door Stopper (for Upper Track)	(7) Door Stopper (Floor Mount)		
Item Code		250-033-810	250-033-812	250-041-954	250-029-718	250-041-955	250-041-956		250-019-971
Item Name		FD35EV-WRH-DSC	FD35EV-WRH-N	FD35EV-TRA-TRG	FD50-BGR18	FD35EV-TRA-STP	FD35EV-FSTP		FD30-HBRT1500SIL
Two-Way Soft Close Type	Length 2120 mm x 1 pc	1 pc	1 pc	1Set	1 pc	2 pcs	2 pcs	1 set (Grey) 250-022-273 FD30-HASC-GR 1 set (Brown) 250-022-449 FD30-HASC-BR 1 set (White) 250-025-640 FD30-HASC-WT	1 pc
Set of necessary parts for sliding doors Item Code: 250-041-953 Item Name: FD35EVDHCP-AK									

\*1 Includes Trigger Installation Jig and spanner. Can also be purchased separately.

ARCHITECTURAL DOOR HARDWARE TOP MOUNTED SLIDING DOOR

### Installation Example

- \*2 The gap between the upper track and the door can be adjusted within a range of -3 mm to +4 mm.
- \*3 The horizontal position can be adjusted within a range of -2 mm to +2 mm from the end of the door.

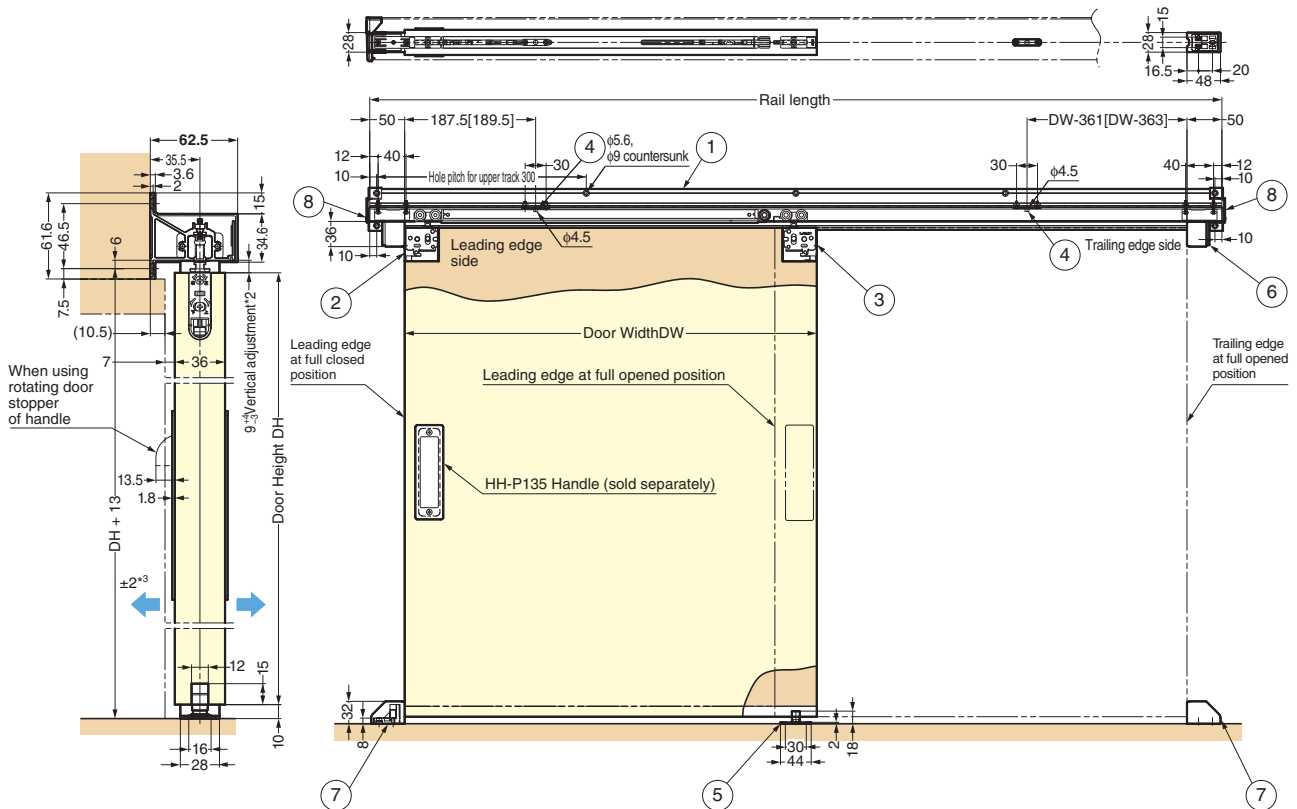

[ ] indicates the dimensions when the upper roller cover cap (optional) is attached.

### Cut Out Dimensions

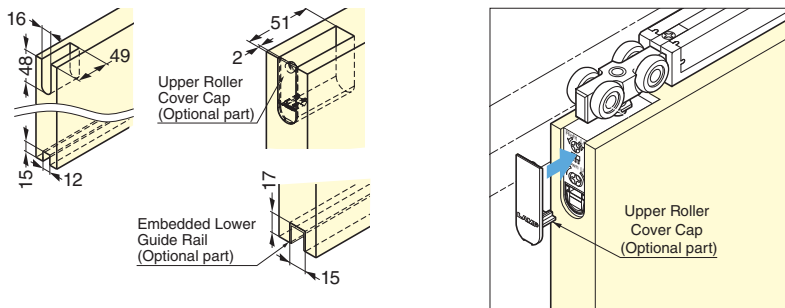

### Door Adjustment

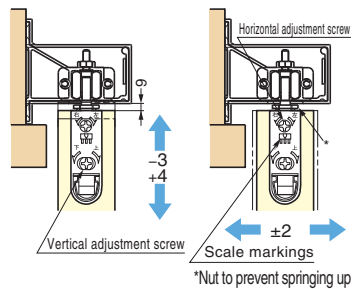

- Can be adjusted with one ⊕No. 2 screwdriver.
- Scale markings are provided for horizontal adjustment from the end of the door.

### Internal mechanism prevents bouncing during closing

Prevents the door from bouncing up after the soft close function has been activated.

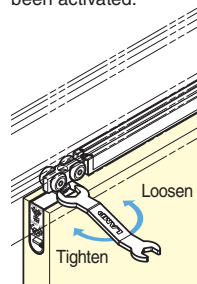

After adjusting, tighten the spring-up prevention nuts (necessary parts (2) and (3)) using the spanner (included with closer) with a nominal size of 12 until the nuts come into contact with the upper track.

### Type of Outset Upper Track

Included screws: Size 4 x 40 cross-recessed flat head tapping screws

Specifications	Length	Silver		Amber		White	
		Item Code	Item Name	Item Code	Item Name	Item Code	Item Name
(1) Outset Upper Track	2120 mm	250-041-957	FD35EV-TRA2120-SL	250-041-958	FD35EV-TRA2120-UM	250-041-959	FD35EV-TRA2120-WT
	2420 mm	250-041-960	FD35EV-TRA2420-SL	250-041-961	FD35EV-TRA2420-UM	250-041-962	FD35EV-TRA2420-WT
	2720 mm	250-041-963	FD35EV-TRA2720-SL	250-041-964	FD35EV-TRA2720-UM	250-041-965	FD35EV-TRA2720-WT