

OUTSET SLIDING DOOR SYSTEM



FD30-H

Door Weight	Max. 30 kg/Door
Door Thickness	30 - 36 mm
Door Width	590 - 1000 mm
Door Height	Max. 2400 mm
Height Adjustment	-3/+4 mm
Side Adjustment	±2 mm

Features

- Can be retrofitted onto existing entranceways.
- Self closes (pulls door to closed position) when 100mm away. Door also opens lightly.
- Within 50mm of being fully open, will automatically open.
- 2 sequence soft-close on both sides makes doors open and close gently, preventing shutting.
- Passed 200,000 open and close cycles in a private test.
- *Designed for interior use.

Door Preparation

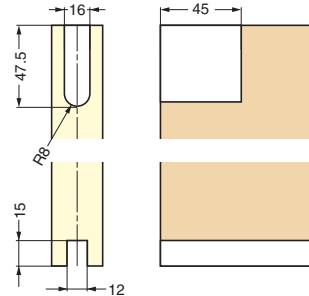

ARCHITECTURAL DOOR HARDWARE

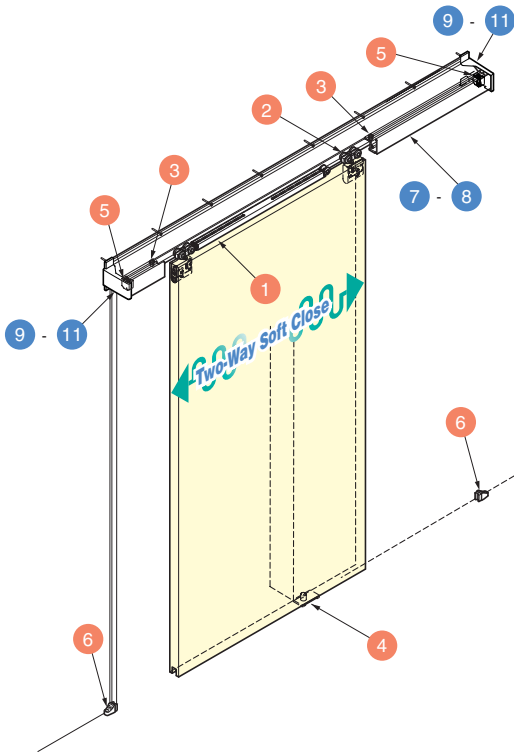

Installation Example
(In case of 33 mm door thickness)

OUTSET SLIDING DOOR SYSTEM

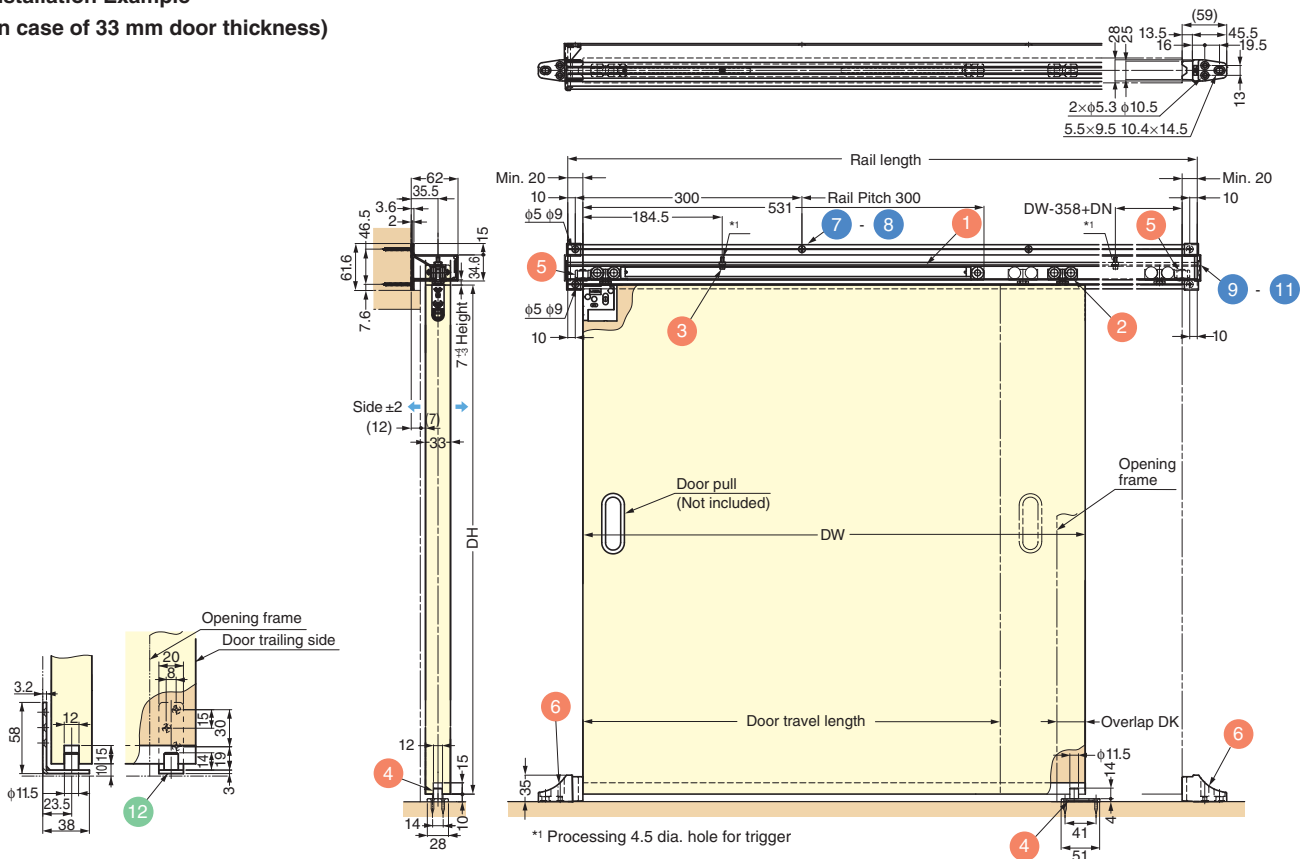

**Parts Set
(Per Door)**

Necessary Parts

Item Code	Item Name	Description
250-022-275	FD30DHCP-AK	Two-Way Soft Close / Outset Use

Parts Included

No.	Qty	Part Name	Dimensions	Description
1	1 pc	Recessed Roller Two-Way Soft Close		Item Code : 250-026-118 Item Name : FD30-WRH-DSC-A • Material Zinc Alloy (ZDC) / Polyacetal (POM) • Finish Yellow Zinc Chromate / Light Brown • Screw Pan Head Tapping Screw 3.5x30
2	1 pc	Recessec Roller		Item Code : 250-020-837 Item Name : FD30-WRH-N • Material Zinc Alloy (ZDC) / Polyacetal (POM) • Finish Yellow Zinc Chromate / Light Brown • Screw Pan Head Tapping Screw 3.5x30
3	1 set	Trigger for Outset Use		Item Code : 250-022-274 Item Name : FD30-HATG • Material Steel • Finish Chromate 2 pcs, M4 Nuts
4	1 pc	Floor Guide		Item Code : 250-017-151 Item Name : FD30-HBG-LBR • Material Steel / Polyamide (PA) • Finish Yellow Zinc Chromate / Light Brown • Screw Countersunk Head Tapping Screw 3.5x30 White, Dark Brown are also available.
5	2 pcs	Bumper Block		Item Code : 250-022-265 Item Name : FD30-HBB • Material Steel / Ethylene Propylene Rubber (EPDM) • Finish Chromate / Black
6	2 pcs	Door Stopper (Floor)		Item Code : 250-018-497 Item Name : FD30-HTKY • Material Zinc Alloy (ZDC) / Rubber • Finish Matte Silver / Black Application For floor mount application. • Screw Binding Head Tapping Screw 4x30

Upper Track

Necessary Parts

No.	Length	Item Code	Part Name	Dimensions	Description
7	2100 mm	250-022-269	Silver		• Material Aluminium Alloy • Finish Anodized Silver +Clear • Screw Countersunk Head Tapping Screw 4x40
		Item Name FD30-TRA2100SL			
8	2730 mm	250-022-271	Silver	Hole Pitch 300 mm Pitch End 10 mm	
		Item Name FD30-TRA2730SL			

Side Cover

Necessary Parts

No.	Colour	Item Code	Part Name	Dimensions	Description
9	Grey (Set for L&R)	250-022-273	Item Name FD30-HASC-GR		• Material Steel / ABS • Finish/Colour Chromate / Grey • Screw Cross-recessed Head Machine Screw 4x25 (φ6)
10	Brown (Set for L&R)	250-022-449	Item Name FD30-HASC-BR		
11	White (Set for L&R)	250-025-640	Item Name FD30-HASC-WT		

Optional Parts

No.	Item Code	Part Name	Dimensions	Description
12	250-019-968	Guide Roller for Wall		• Material Steel / Polyacetal (POM) • Finish Yellow Zinc Chromate / Light Brown Application For wall mount application. • Screw Countersunk Head Tapping Screw 3.5x30
	Item Name FD30-HBGK			

ARCHITECTURAL
DOOR HARDWARE

OUTSET SLIDING DOOR SYSTEM