

TWIN WHEEL CASTER (PLATE TYPE)

GX75P

GX75P
w/o BrakeGX75PS
w/ Brake

Features

- Thanks to the light weight aluminium body, the caster is strong and smart looking.
- Twin wheel caster with excellent stability.

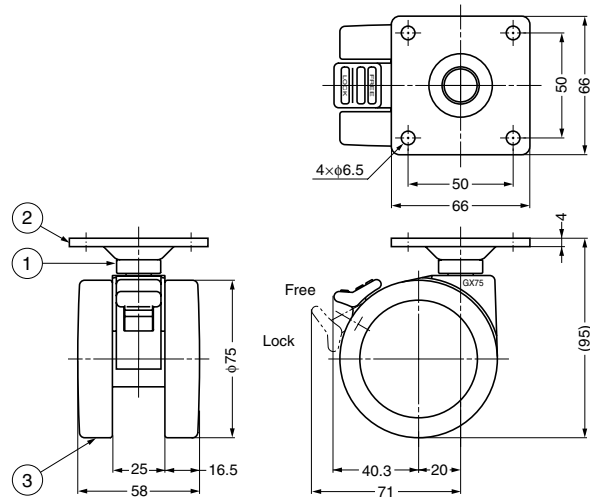

No.	Part Name	Material	Finish/Colour
①	Body	Aluminium Alloy	Polished
②	Plate	Steel	Yellow Zinc Chromate
③	Wheel	Polyamide (PA)	Black

Item Code	Item Name	Type	Load Capacity N	Load Capacity kgf	Weight	Box	Carton
200-133-218	GX75PS	With Brake	1960 N	200 kgf	453 g	2 pcs	24 pcs
200-133-217	GX75P	Without Brake	1960 N	200 kgf	444 g	2 pcs	24 pcs

TWIN WHEEL CASTER (THREADED BOLT TYPE)

GX75N16

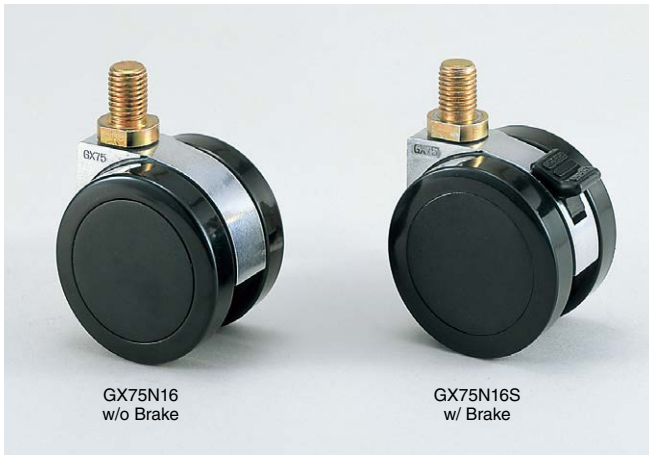
GX75N16
w/o BrakeGX75N16S
w/ Brake

Features

- Thanks to the light weight aluminium body, the caster is strong and smart looking.
- Twin wheel caster with excellent stability.

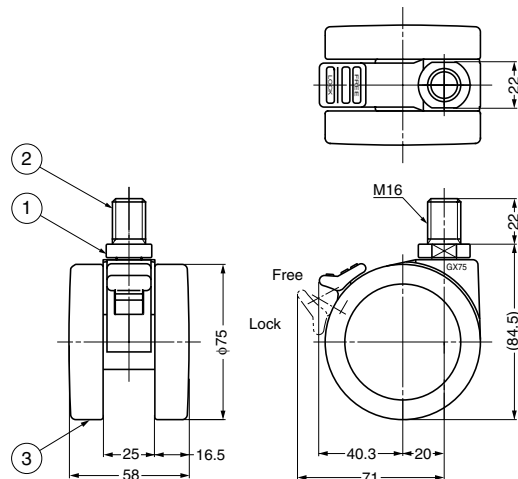

No.	Part Name	Material	Finish/Colour
①	Body	Aluminium Alloy	Polished
②	Threaded Bolt	Steel	Yellow Zinc Chromate
③	Wheel	Polyamide (PA)	Black

Item Code	Item Name	Type	Load Capacity N	Load Capacity kgf	Weight	Box	Carton
200-133-220	GX75N16S	With Brake	1960 N	200 kgf	350 g	2 pcs	24 pcs
200-133-219	GX75N16	Without Brake	1960 N	200 kgf	340 g	2 pcs	24 pcs