

# Series QX twin cylinders

1

MOVEMENT

Double-acting, magnetic, guided  
 ø 10x2, 16x2, 20x2, 25x2, 32x2 mm



- » High force
- » Precise movement
- » Integrated guide
- » QXB: linear ball bearings
- » QXT: sintered bronze bushes

Series QX actuators offer a wide range of solutions covering a great number of applications which require a guided linear movement. The design of the double piston, besides assuring a solid and effective guide, offers double force in compact dimensions.

Where a high force with precise movement is required, along with a non-rotation function and integrated guide, the QX cylinders are the ideal solution.

The range includes two guide versions with sintered bronze bushes or with linear ball bearings.

## GENERAL DATA

<b>Type of construction</b>	compact, non magnetic QXT = sintered bronze bushes - QXB = linear ball bearings
<b>Operation</b>	double-acting
<b>Materials</b>	body and flange = anodized AL QXT piston rod = stainless steel AISI 303 - QXB piston rod = hardened steel C50 seals = PU
<b>Mounting method</b>	by means of threaded holes
<b>Strokes</b>	from 10 to 100
<b>Operating temperature</b>	0° ÷ 80°C (with dry air - 20°C)
<b>Operating speed</b>	50 ÷ 500 mm/s
<b>Operating pressure</b>	1 ÷ 10 bar
<b>Fluid</b>	clean air, without lubrication. If lubricated air is used, it is recommended to use oil ISOVG32. Once applied the lubrication should never be interrupted.

**STANDARD STROKES FOR TWIN CYLINDERS SERIES QX**

■ = Double-acting

STANDARD STROKES								
∅	10	20	30	40	50	75	100	
10	■	■	■	■	■	■	■	
16	■	■	■	■	■	■	■	■
20	■	■	■	■	■	■	■	■
25	■	■	■	■	■	■	■	■
32	■	■	■	■	■	■	■	■

**CODING EXAMPLE**

<b>QX</b>	<b>T</b>	<b>2</b>	<b>A</b>	<b>020</b>	<b>A</b>	<b>050</b>
-----------	----------	----------	----------	------------	----------	------------

<b>QX</b>	SERIES					
<b>T</b>	VERSION T = sintered bronze bushes B = linear ball bearings					
<b>2</b>	OPERATION 2 = double-acting (1 flange) radial / axial pressure supply 3 = double-acting through-rod (double-flange), radial pressure supply				PNEUMATIC SYMBOLS CD15 CD16	
<b>A</b>	MATERIALS A = anodized aluminium body, rolled stainless steel AISI 303 piston rod					
<b>020</b>	BORE 010 = 10 mm - 016 = 16 mm - 020 = 20 mm - 025 = 25 mm - 032 = 32 mm					
<b>A</b>	TYPE OF DESIGN A = standard					
<b>050</b>	STROKE (see the table)					

**PNEUMATIC SYMBOLS**

The pneumatic symbols which have been indicated in the CODING EXAMPLE are shown below.

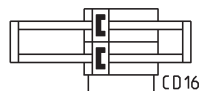
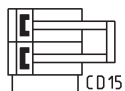

Fixing examples with flange in motion

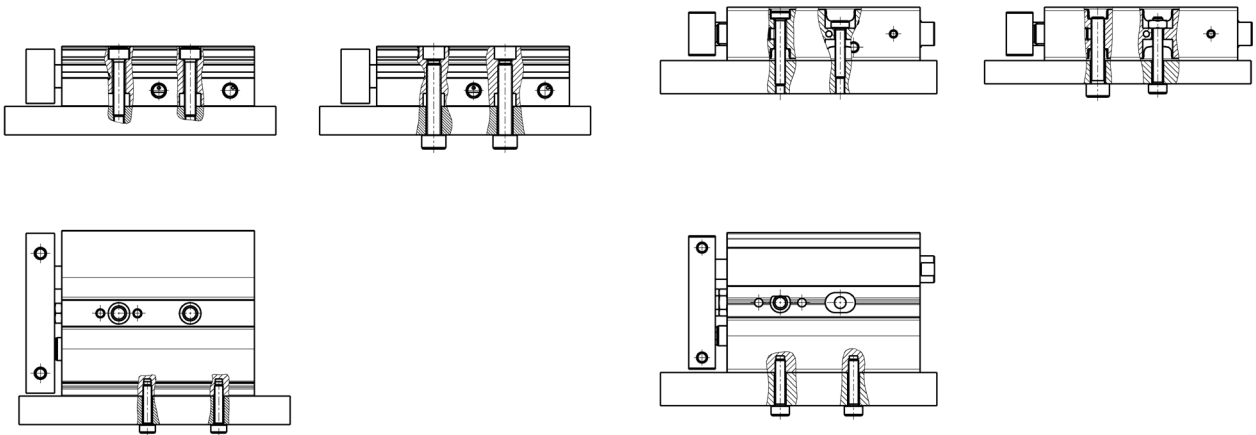

For diameters from 16 to 32

To mount the sensors of QX cylinders  $\varnothing 10$  in the middle grooves, it is advisable to use M3 screws UNI 9327 and nuts M3 UNI 5589.

Fixing examples with cylinder body in motion

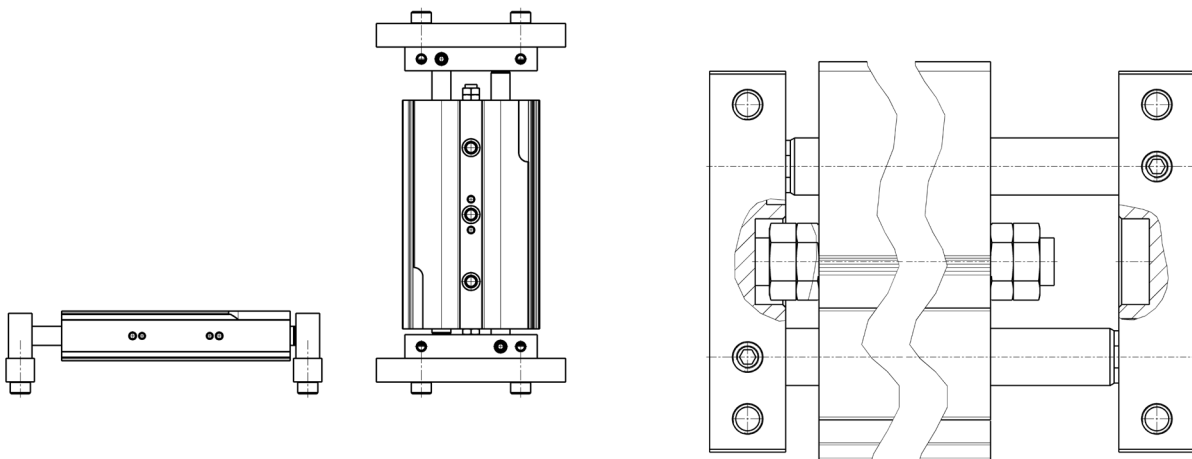

The front and rear regulation screw allows the adjustment of the stroke up to  $-10\text{mm}$ .

## DIAGRAM OF MAX APPLICABLE LOADS DEPENDING ON THE STROKE ( X )

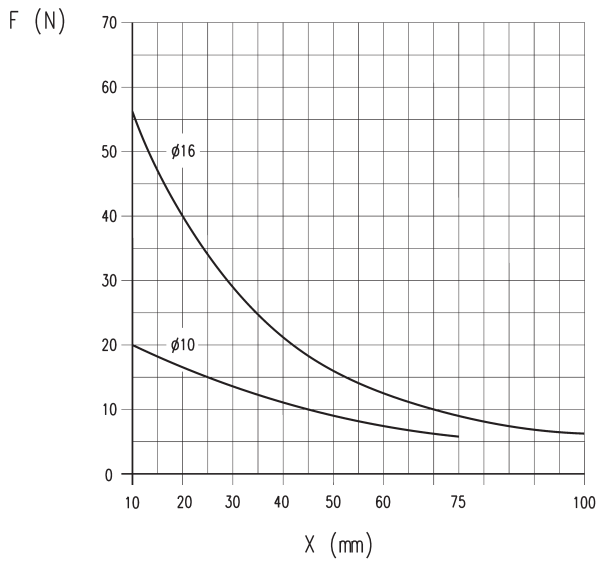

$X$  = cylinder stroke mm.  
 $F$  = load applied on the flange in N.

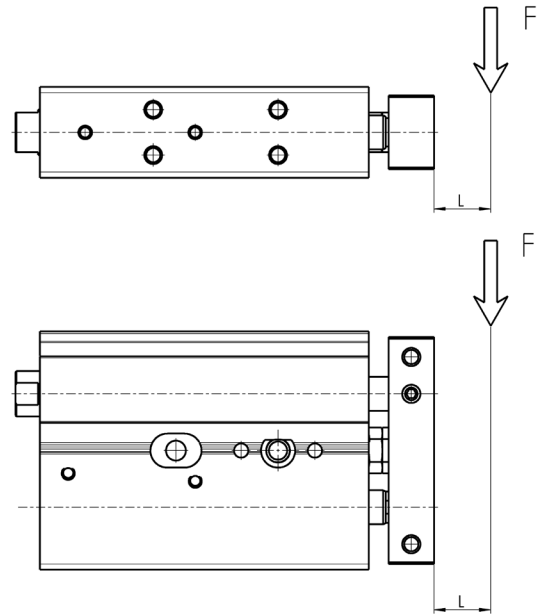

Load " $F$ " should be considered fixed on the flange of the cylinder and with a theoretical projection of  $L = 0$  mm.

## DIAGRAM OF MAX APPLICABLE LOADS DEPENDING ON THE STROKE ( X )

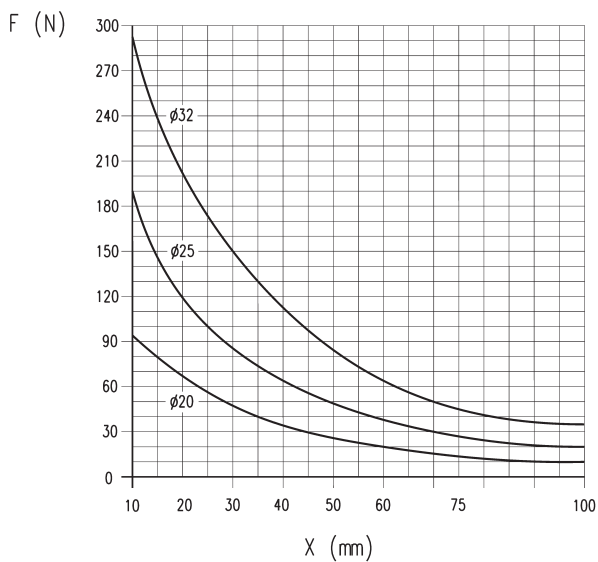

$X$  = cylinder stroke mm.  
 $F$  = load applied on the flange in N.

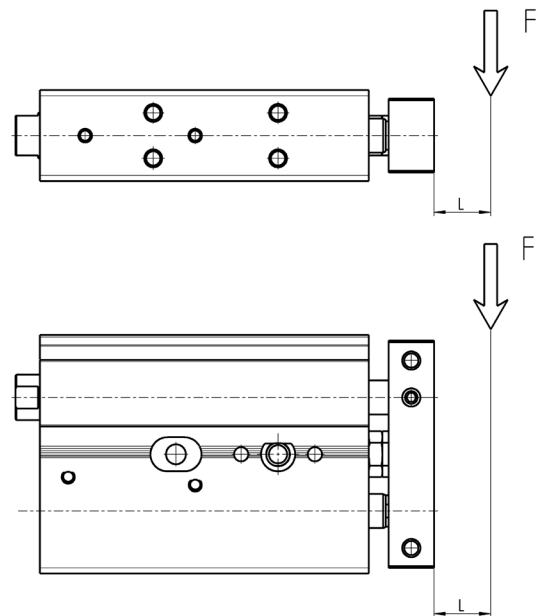

Load " $F$ " should be considered fixed on the flange of the cylinder and with a theoretical projection of  $L = 0$  mm.

DIAGRAM OF MAX TORQUE MOMENT DEPENDING ON THE STROKE (X)

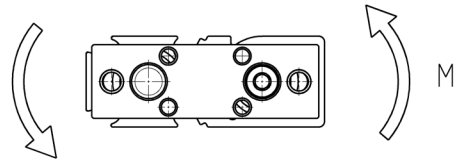
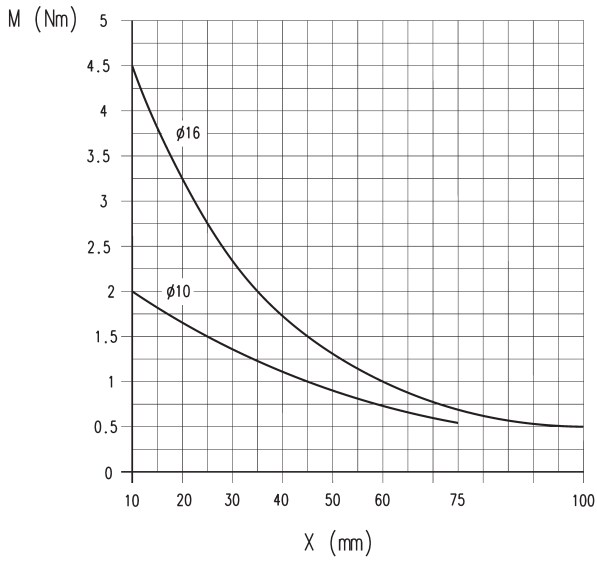

X = cylinder stroke in mm.  
M = torque moment applied on the flange in Nm.

DIAGRAM OF MAX TORQUE MOMENT DEPENDING ON THE STROKE (X)

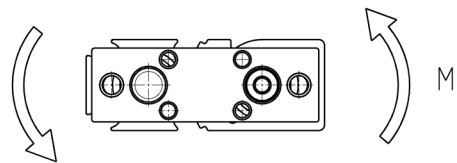
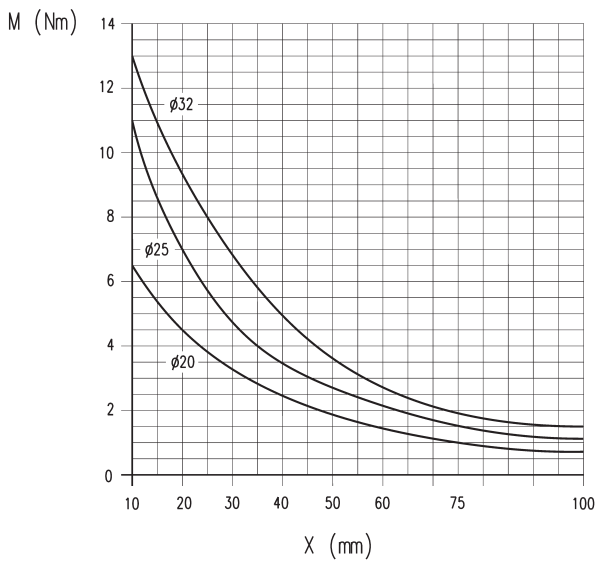

X = cylinder stroke in mm.  
M = torque moment applied on the flange in Nm.

## Cylinders Series QX ( single flange )

NOTE: for out of standard intermediate strokes (ex. stroke 37), you have to consider the dimensions referring to the immediately higher stroke (ex. stroke 40) with a maximum permitted reduction of 10 mm.

+ = add the stroke

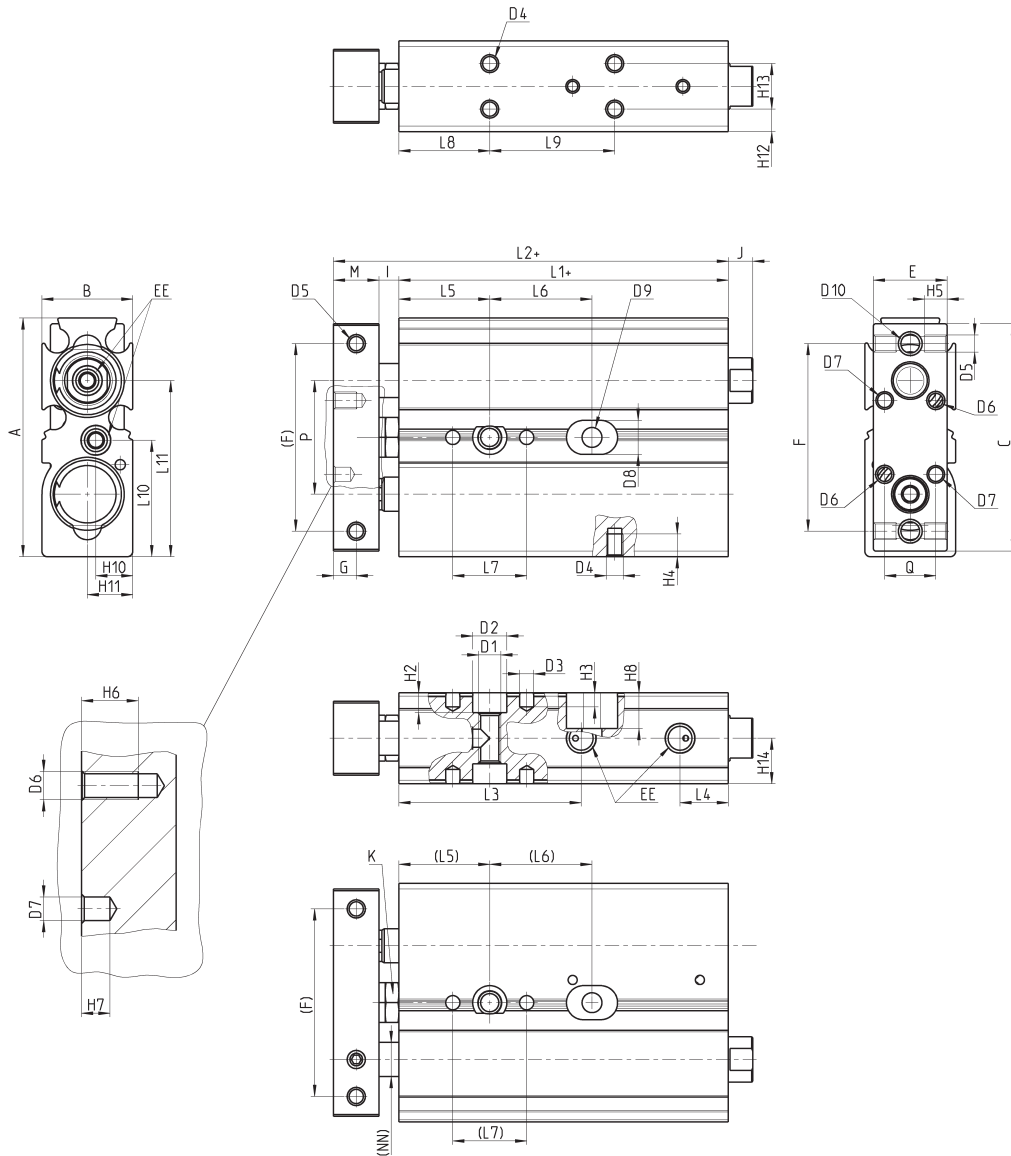

## Dimensions for Series QX with single flange

+ = add the stroke

DIMENSIONS						
Stroke (mm)	Ø 10	Ø 16	Ø 20	Ø 25	Ø 32	
<b>A</b>	42	58	62	76	94	
<b>B</b>	16	21	25	30	37	
<b>C</b>	40	56	60	71	92	
<b>E</b>	13	19	22	27	35	
<b>F</b>	33	42	50	60	75	
<b>G</b>	4	5	6	6	8	
<b>I</b>	3,5	2,5	4,5	4,5	4	
<b>M</b>	8	10	12	12	16	
<b>Q</b>	9	11	16	16	16	
<b>R</b>	13	13	18	18	18	
<b>L1+</b>	48	57,5	67,5	70,5	80,5	
<b>L2+</b>	59,5	70	84	87	100,5	
<b>L3</b>	32,1	34	39,5	44,0	46,5	
<b>L4</b>	8,5	8,5	9	8,5	12	
<b>L5</b>	16	20	25	30	30	
<b>L6</b>	10	18	25	30	40	
<b>L6</b>	20	28	25	30	40	
<b>L6</b>	30	38	35	40	50	
<b>L6</b>	40	48	35	40	50	
<b>L6</b>	50	58	35	40	50	
<b>L6</b>	75	83	45	60	70	
<b>L6</b>	100	-	55	60	70	
<b>L7</b>	13	13	20	20	20	
<b>L8</b>	16	30	30	30	30	
<b>L9</b>	10	22	25	30	40	
<b>L9</b>	20	32	25	30	40	
<b>L9</b>	30	42	35	40	50	
<b>L9</b>	40	52	35	40	50	
<b>L9</b>	50	62	35	40	50	
<b>L9</b>	75	87	45	60	70	
<b>L9</b>	100	-	55	60	70	
<b>L10</b>	20,5	29	31	38	47	
<b>L11</b>	31	52	57,2	71,5	47	
<b>H2</b>	3,5	4,5	5,5	6,5	6,5	
<b>H3</b>	2,5	4,0	4,0	4,0	4,0	
<b>H4</b>	4,0	5,0	4,5	5,0	7,5	
<b>H5</b>	6,5	6,0	6,0	6,0	7,5	
<b>H6</b>	8,0	6,0	8,0	8,0	8,0	
<b>H7</b>	3,0	3,0	4,0	4,0	4,0	
<b>H8</b>	6,3	-	-	-	-	
<b>H10</b>	6,5	10,5	10,5	15	8,5	
<b>H11</b>	8	16,5	20,2	21,5	28,5	
<b>H12</b>	4	10,5	8,00	8,5	8,5	
<b>H13</b>	8	-	9,0	13,0	20,0	
<b>H14</b>	8	5,5	12,5	15,0	18,5	
<b>D1</b>	M4	M5	M6	M8	M8	
<b>D2</b>	6	7,5	9,5	10,5	10,5	
<b>D3</b>	2,5	2,5	4	4	4	
<b>D4</b>	M3	M3	M4	M5	M5	
<b>D5</b>	M3	M4	M4	M5	M5	
<b>D6</b>	M3	M3	M4	M4	M4	
<b>D7</b>	2,5	2,5	4,0	4,0	4,0	
<b>D8</b>	6,0	-	-	-	-	
<b>D9</b>	3,5	-	-	-	-	
<b>D10</b>	M4	M5	M5	M6	M6	
<b>NN</b>	6	8	10	12	16	
<b>EE</b>	M5	M5	M5	M5	G1/8	
<b>J</b>	4,3	-	-	-	-	
<b>K</b>	7	7	8	8	10	
<b>P</b>	20	25	29	35	45	

## Cylinders Series QX (double flange)

NOTE: for out of standard intermediate strokes (ex. stroke 37), you have to consider the dimensions referring to the immediately higher stroke (ex. stroke 40) with a maximum permitted reduction of 10 mm.

+ = add the stroke

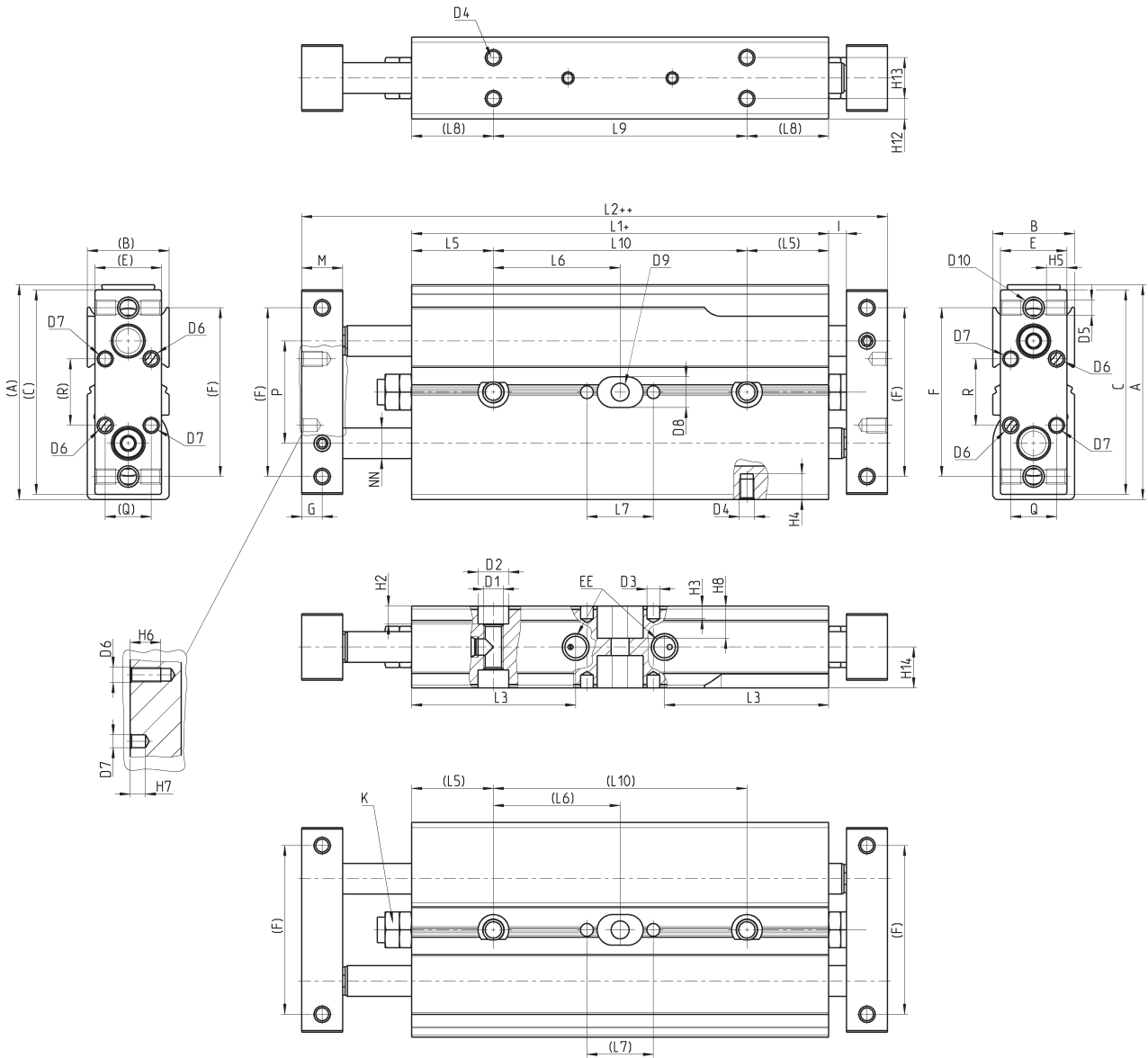



## Dimensions for Series QX with double flange

1

MOVEMENT

+ = add the stroke  
 ++ = add the stroke 2 times

DIMENSIONS						
Stroke (mm)	Ø 10	Ø 16	Ø 20	Ø 25	Ø 32	
<b>A</b>	42	58	62	76	94	
<b>B</b>	16	21	25	30	37	
<b>C</b>	40	56	60	71	92	
<b>E</b>	13	19	22	27	35	
<b>F</b>	33	42	50	60	45	
<b>G</b>	4	5	6	6	6	
<b>I</b>	3,5	2,5	4,5	4,5	4	
<b>M</b>	8	10	12	12	16	
<b>Q</b>	9	11	16	16	16	
<b>R</b>	13	13	18	18	18	
<b>L1+</b>	72	86,6	98	104,2	115,6	
<b>L2++</b>	95	111,6	131	137,2	155,6	
<b>L3</b>	32,1	34	39,5	44	46,5	
<b>L5</b>	16	20	25	30	30	
<b>L6</b>	10	25	28,3	29,0	27,1	32,8
<b>L6</b>	20	30	33,3	34,0	32,1	37,8
<b>L6</b>	30	35	38,3	39,0	37,1	42,8
<b>L6</b>	40	40	43,3	44,0	42,1	47,8
<b>L6</b>	50	45	48,3	49,0	47,1	52,8
<b>L6</b>	75	57,3	60,8	61,5	59,6	65,3
<b>L6</b>	100	-	73,3	74,0	72,1	77,8
<b>L7</b>	13	13	20	20	20	
<b>L8</b>	16	30	30	30	30	
<b>L9</b>	10	49,6	36,6	48	54,2	65,6
<b>L9</b>	20	59,6	46,6	58	64,2	75,6
<b>L9</b>	30	69,6	56,6	68	74,2	85,6
<b>L9</b>	40	79,6	66,6	78	84,2	95,6
<b>L9</b>	50	89,6	76,6	88	94,2	105,6
<b>L9</b>	75	114,6	101,6	113	119,2	130,6
<b>L9</b>	100	-	126,6	138	144,2	155,6
<b>L10</b>	10	49,6	56,6	58,0	54,2	65,6
<b>L10</b>	20	59,6	66,6	68,0	64,2	75,6
<b>L10</b>	30	69,6	76,6	78,0	74,2	85,6
<b>L10</b>	40	79,6	86,6	88,0	84,2	95,6
<b>L10</b>	50	89,6	96,6	98,0	94,2	105,6
<b>L10</b>	75	114,6	121,6	123,0	119,2	130,6
<b>L10</b>	100	-	146,6	148,0	144,2	155,6
<b>H2</b>	6,3	4,5	5,50	6,5	6,5	
<b>H3</b>	2,5	4,0	4,00	4	4	
<b>H4</b>	4	5,0	4,50	5	7,5	
<b>H5</b>	6,5	6,0	6,00	6	7,5	
<b>H6</b>	8	6,0	8,00	8	8	
<b>H7</b>	3	3,0	4,00	4	4	
<b>H8</b>	6,3	-	-	-	-	
<b>D1</b>	M4	M5	M6	M8	M8	
<b>D2</b>	6	7,5	9,5	10,5	10,5	
<b>D3</b>	2,5	2,5	4	4	4	
<b>D4</b>	M3	M3	M4	M5	M5	
<b>D5</b>	M3	M4	M4	M5	M5	
<b>D6</b>	M3	M3	M4	M4	M4	
<b>D7</b>	2,5	2,5	4	4	4	
<b>D8</b>	6	-	-	-	-	
<b>D9</b>	3,5	-	-	-	-	
<b>D10</b>	M4	M5	M5	M6	M6	
<b>NN</b>	6	8	10	12	16	
<b>EE</b>	M5	M5	M5	M5	G1/8	
<b>K</b>	7	7	8	8	10	
<b>P</b>	20	25	29	35	40	