

HEAVY-DUTY VERTICAL CLAMPS

VA700 SERIES MODEL VA700/2C



for pneumatic models
see page 14



for locking mechanism in "open position"
add suffix (LC) to model number



Arm:
The spindle is in a fixed position.

Base:
Flanged.

Nominal Holding Force:
700 daN

Weight:
1.25 Kg

Supplied complete with:
MB12100 Setscrew & nuts.

See "Accessories" for other items.

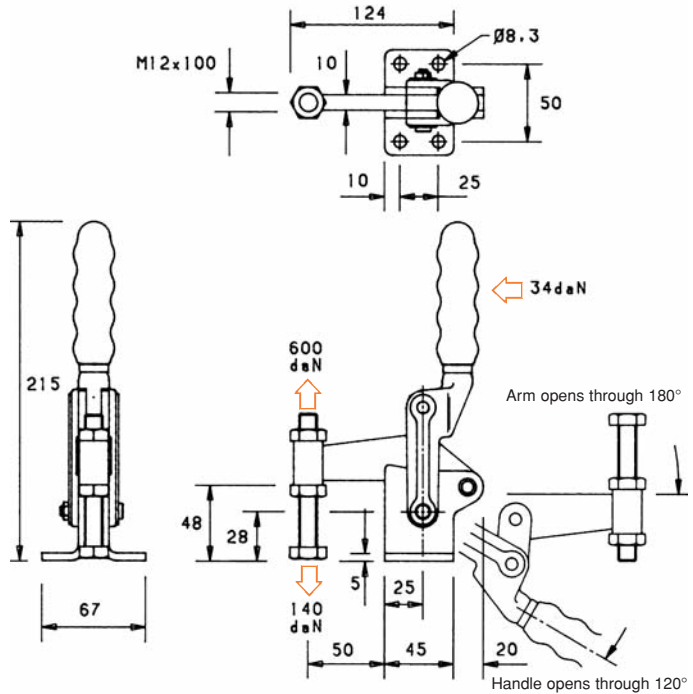

VA700 SERIES MODEL VA700TD



for pneumatic models
see page 14

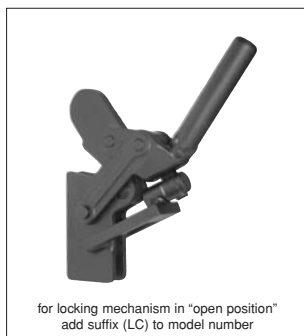

for locking mechanism in "open position"
add suffix (LC) to model number



Arm:
Stub nose with mounting holes.

Base:
Straight with mounting holes.

Nominal Holding Force:
700 daN

Weight:
1.01kg

See "Accessories" for other items.

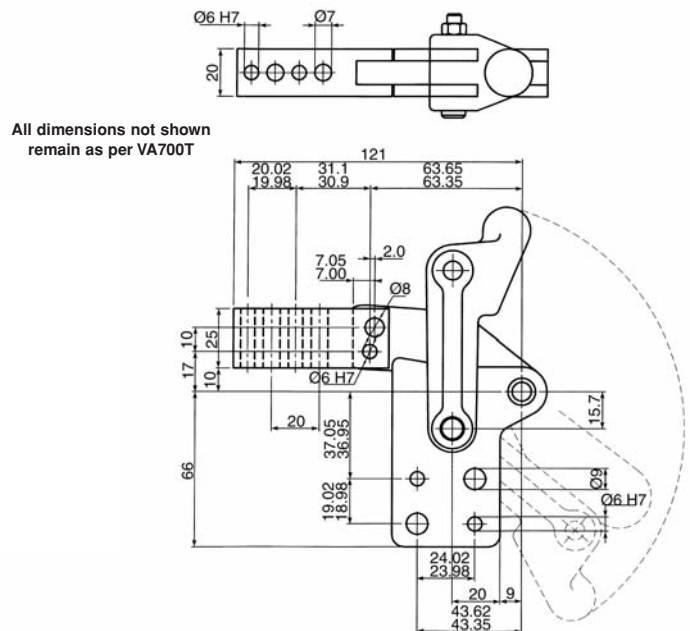

All dimensions not shown
remain as per VA700T

