

VERTICAL CLAMPS

V200 SERIES

MODEL V200/1B



Arm:
The spindle is in a fixed position.

Base:
Flanged.

Nominal Holding Force:
150 daN

Weight:
0.15 Kg

Supplied complete with:
MB0650 Setscrew & nuts.
NC/06 Neoprene cover.

See "Accessories" for other items.

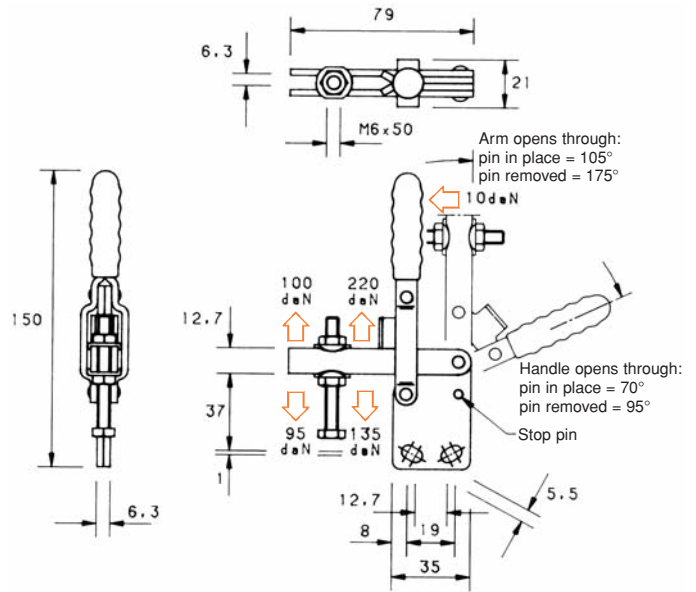

V200 SERIES

MODEL V200/1C



Arm:
The spindle is in a fixed position.

Base:
Straight.

Nominal Holding Force:
200 daN

Weight:
0.20 Kg

Supplied complete with:
MB0650 Setscrew & nuts.

See "Accessories" for other items.

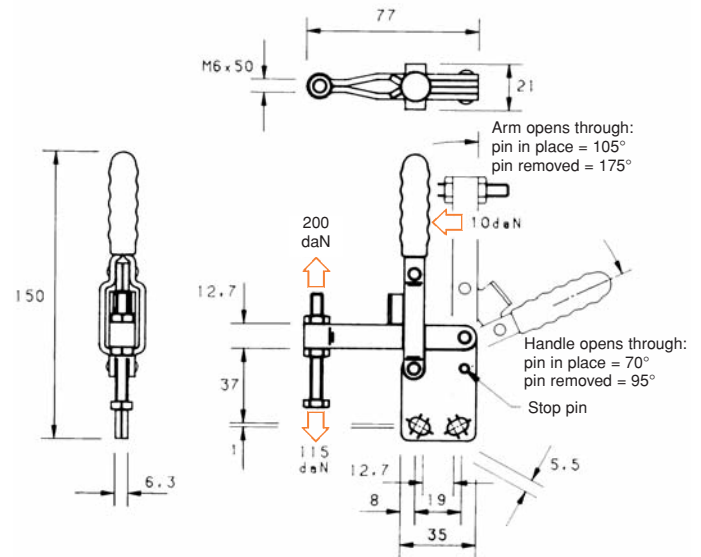

V200 SERIES

MODEL V200/2B



Arm:
The spindle position is adjustable along the arm.

Base:
Flanged.

Nominal Holding Force:
200 daN

Weight:
0.20 Kg

Supplied complete with:
MB0650 Setscrew & nuts.
FW06/12 Flanged washers.

See "Accessories" for other items.

