

HORIZONTAL CLAMPS

H350 SERIES

MODEL H350/2B

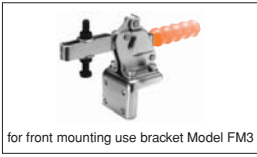

Arm:
The spindle position is adjustable along the arm.

Base:
Flanged.

Nominal Holding Force:
350 daN

Weight:
0.90 Kg

Supplied complete with:
MB1080 Setscrew & nuts.
FW10/20 Flanged washers.

See "Accessories" for other items.

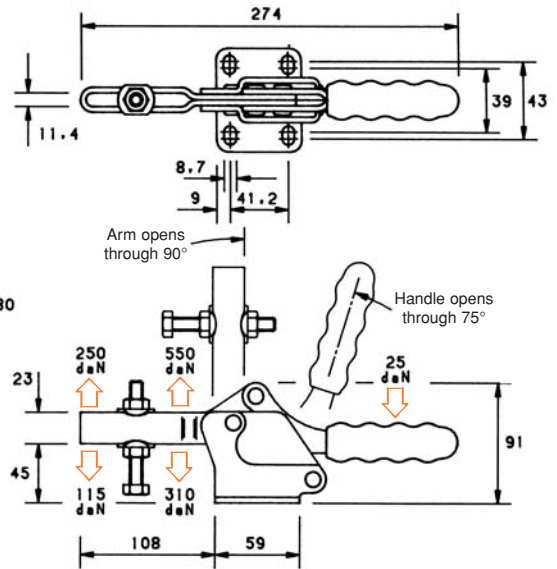

H450 SERIES

MODEL H450/1A



Arm:
Solid with spindle retainer supplied loose for welding in the desired position.

Base:
Straight.

Nominal Holding Force:
450 daN

Weight:
1.60 Kg

Supplied complete with:
MB12100 Setscrew & nuts.
R/12 Spindle retainer.

See "Accessories" for other items.

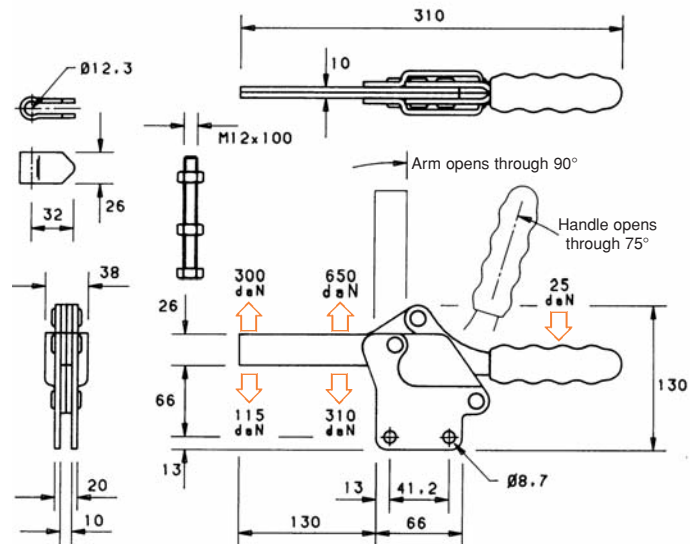

H450 SERIES

MODEL H450/1B



Arm:
The spindle position is adjustable along the arm.

Base:
Straight.

Nominal Holding Force:
450 daN

Weight:
1.60 Kg

Supplied complete with:
MB12100 Setscrew & nuts.
FW12/23 Flanged washers.

See "Accessories" for other items.

