

ADDITIONAL HORIZONTAL CLAMPING PRODUCTS

MODEL H200/1B



Arm:
The spindle position is adjustable along the arm.

Base:
Straight.

Nominal Holding Force:
200 daN

Weight:
0.17 Kg

Supplied complete with:
standard spindle, nuts and flanged washers

See "Accessories" for other items.

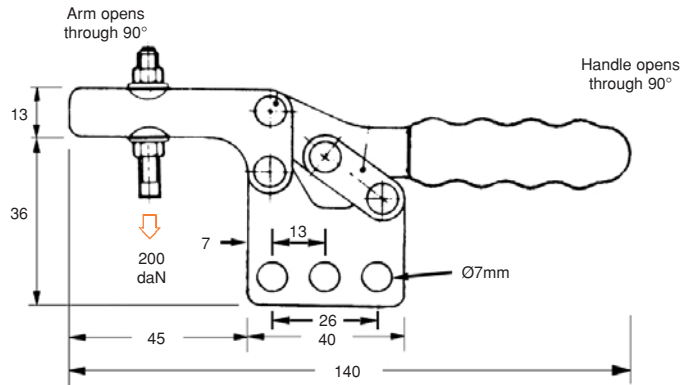

MODEL H200/2B



Arm:
The spindle position is adjustable along the arm.

Base:
Flanged.

Nominal Holding Force:
200 daN

Weight:
0.17 Kg

Supplied complete with:
standard spindle, nuts and flanged washers

See "Accessories" for other items.

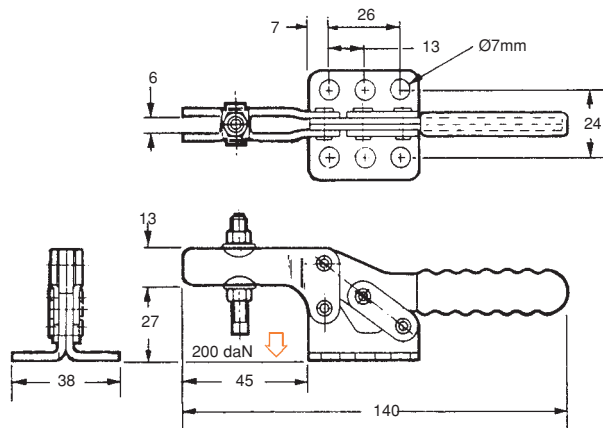

MODEL H200/3B



Arm:
The spindle position is adjustable along the arm.

Base:
Front mounting.

Nominal Holding Force:
200 daN

Weight:
0.17 Kg

Supplied complete with:
standard spindle, nuts and flanged washers

See "Accessories" for other items.

