

Linear Encoder LE200

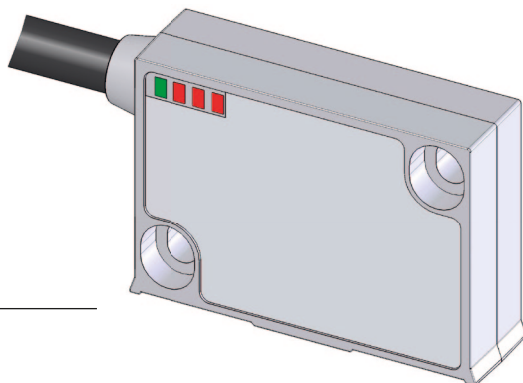

SIKO GmbH

Address
 Weihermattenweg 2
 79256 Buchenbach

Telephone
 +49 7661 394-0

Fax
 +49 7661 394-388

eMail
 info@siko.de
Internet
 www.siko-global.com

Features:

- robust metal housing
- LED status display
- easy mounting
- signal period 2000 μm
- scale MB200/1
- insensitive to dust, shavings, humidity

Signals:

- E: reference voltage 2.5 V ±100 mV
- F: 1 Vpp ±10 %
- J: ≥0.2 V
- L: 100° ±20°
- M: 90° ±1.0° / <±3° (20 m/s)
- X: 1 Vpp
- K: ≥0.3 V

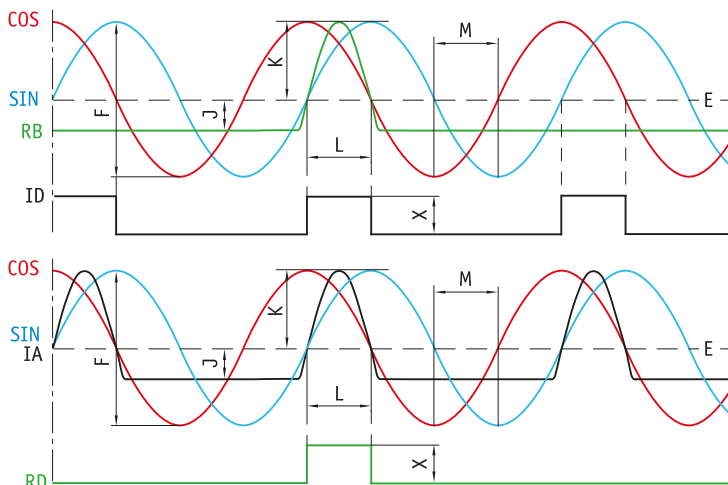

Feature	Order text	Additional information	
Operating voltage	10 A	10.5 ... 30 V DC	
	5	5 V DC ±5 %	
Design	M B		
	AM	Form A, metal	
	A		
Connection	E1 C		
	E6X		
	E6		
Cable length L (in m)	... D	max. 20.0 m	
Cable length L2 (in m)	... E	L + L2 = max. 20.0 m	
Reference signal	0 F	without	
	IA	periodic index (analog)	all 2 mm index signal
	ID	periodic index (digital)	all 2 mm index signal
	RB	fixed, tape side (analog)	
	RD	fixed, tape side (digital)	

Your ordering: - - - - - -

Linear Encoder LE200

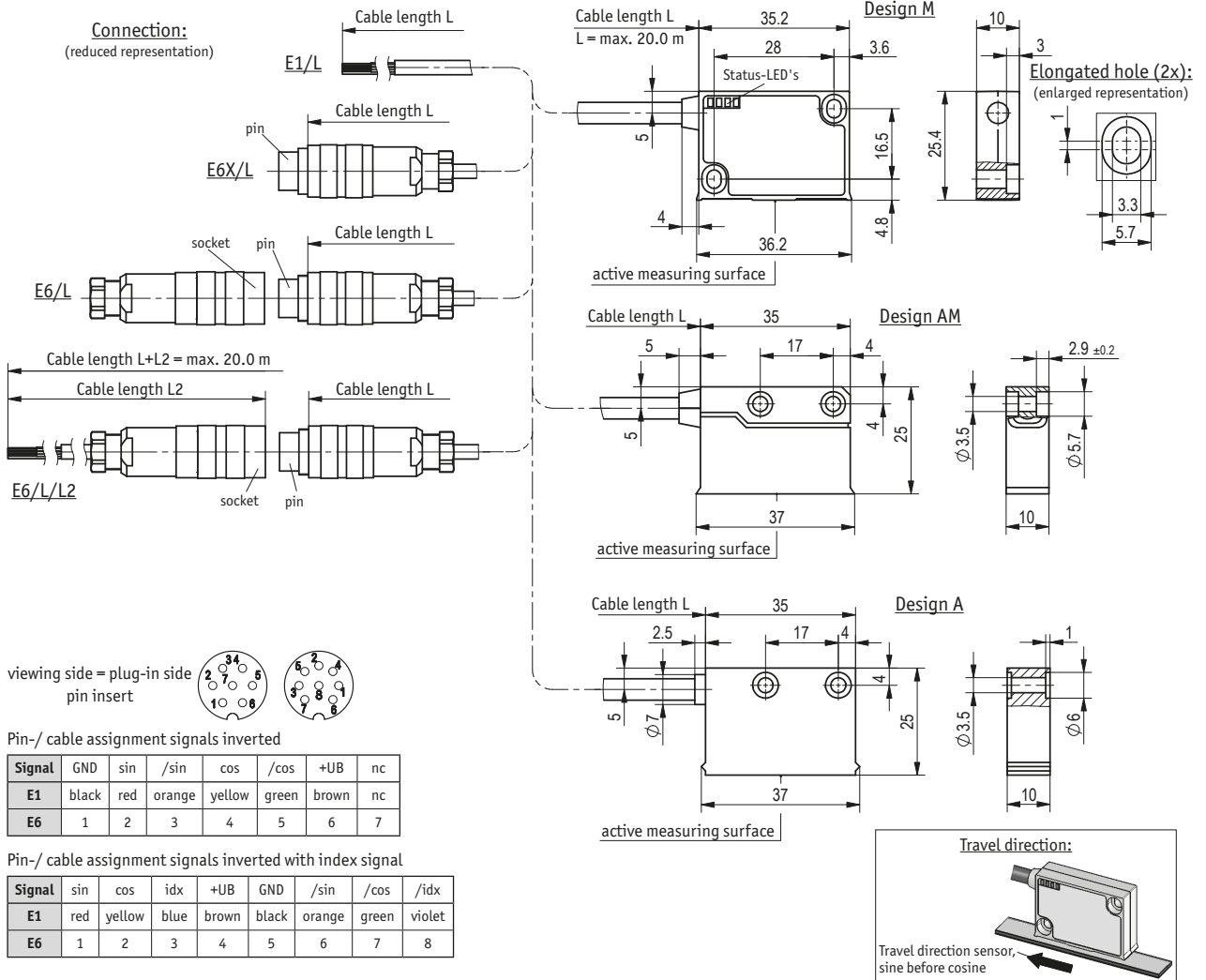

Technical data

Mechanical data	
Housing	zinc/aluminum die-cast, nickel-plated, M, AM design green plastic, A design
Sensor/band reading distance	0.1 ... 0.8 mm O, IA, IB reference signal 0.1 ... 0.5 mm RB, RD reference signal
Cable sheath	PUR dragchain-compatible 6, 8 wire $\phi_{5-0.4}$ mm
Cable bending radius	5x cable diameter, statical 7.5x cable diameter, dynamical
Service life of cable	>5 million cycles under the following test conditions: Travel range 4.5 m Travel speed 3 m/s Acceleration 5 m/s ² Ambient temperature 20 °C \pm 5 °C
Weight	0.03 kg (without cable)
Electrical data	
Operating voltage	10.5 ... 30 V DC 5 V DC \pm 5 %
Current consumption	<25 mA, at 24 V DC <50 mA, at 5 V DC
Output signals	sin, /sin, cos, /cos, index, /index
Output voltage	1 V _{pp} \pm 10 %, at 0 ... 70 °C
Output current	\leq 60 mA peak, 5 s, per core
Output impedance	0 Ω ($R_{load} > 75 \Omega$), short-circuit proof
Signal period	2000 μ m
Offset voltage	2.5 V, \pm 100 mV, sine/cosine mean to GND (10.5 ... 30 V DC) UB/2 \pm 100 mV, sine/cosine mean to GND (5 V DC)

Technical data

Phasing	90° \pm 1°, \pm 3° (20 m/s), sin/cos 45°, sin (reference signal) 135°, cos (reference signal)
Type of connection	open cable end plug connector, 7/8 pole
System data	
System accuracy	25 μ m, at T ₀ = 20 °C
Repeat accuracy	4 μ m unidirectional
Travel speed	\leq 25 m/s \leq 5 m/s RB, RD reference signal
Ambient conditions	
Ambient temperature	-10 ... 70 °C
Storage temperature	-30 ... 80 °C
Relative humidity	100 % condensation admissible
EMC	EN 61000-6-2, interference resistance/immission EN 61000-6-4, emitted interference/emission
Protection category	IP67, EN 60529
Shock resistance	500 m/s ² , 11 ms, EN 60068-2-27
Vibration resistance	200 m/s ² , 50 Hz ... 2 kHz, EN 60068-2-6
Accessory	
	2x hexagon socket head cap screw, (ISO 4762-M3x14) separately enclosed 2x lock washer, (3 DIN 7980) separately enclosed