

6

5

4

3

2

1

REVISION HISTORY			
REV	DATE	BY	DESCRIPTION
A	19 JAN 2009	M Waldren	PRN: P2009-0022
B	13 APR 2010	YGC/ACH	PRN: P2010-0278
C	14 APR 2010	YGC/ACH	PRN: P2010-0339

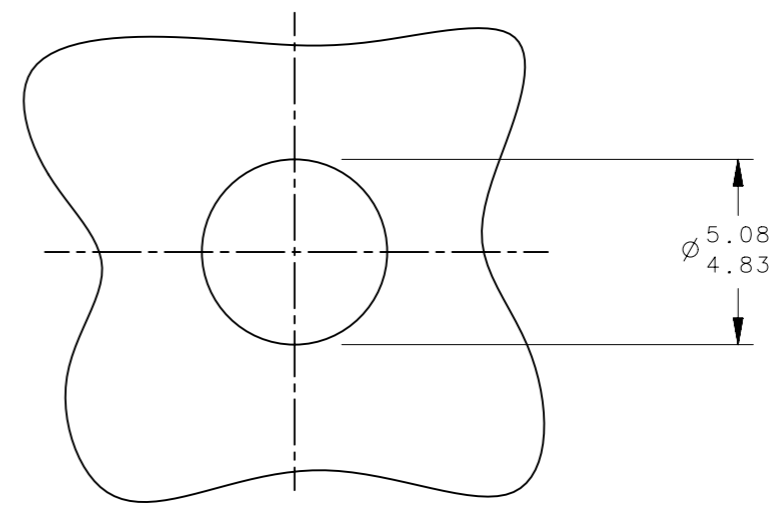
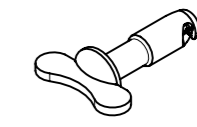
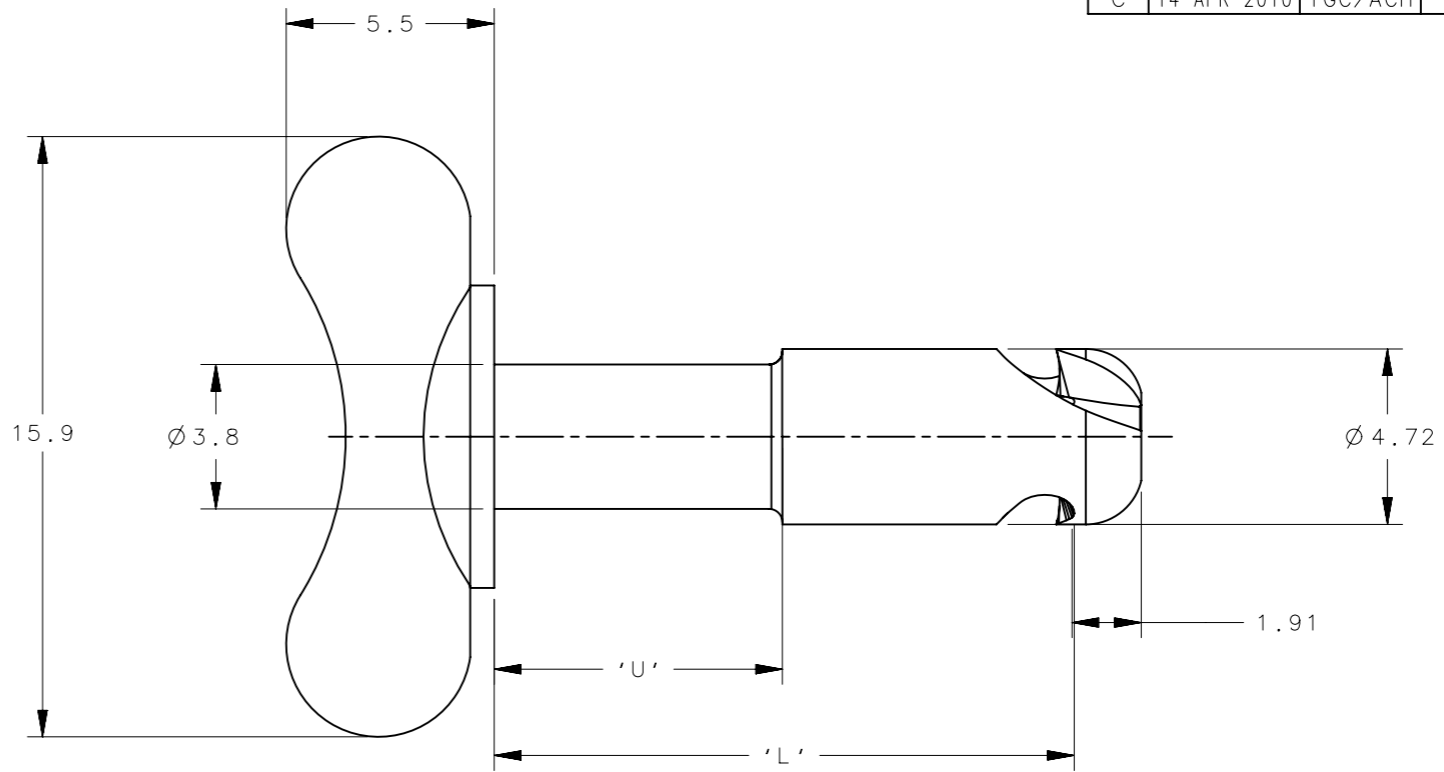
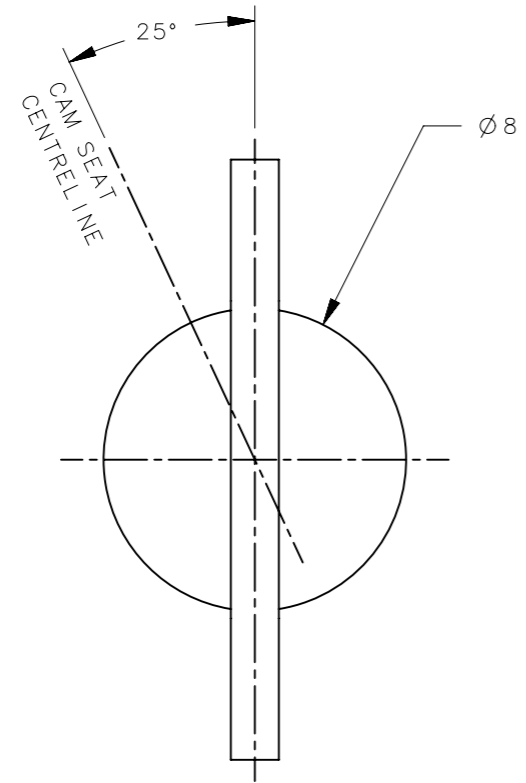

STANDARD PANEL PREPARATION

PART No.	'L'	'U'	PART No.	'L'	'U'
D4-AJW3-25	6.35	1.90	D4-AJW3-120	30.48	12.7
D4-AJW3-30	7.62	2.54	D4-AJW3-130	33.02	12.7
D4-AJW3-35	8.89	3.81	D4-AJW3-140	35.56	12.7
D4-AJW3-40	10.16	5.08	D4-AJW3-150	38.10	12.7
D4-AJW3-45	11.43	5.77	D4-AJW3-160	40.64	12.7
D4-AJW3-50	12.70	6.35	D4-AJW3-170	43.18	12.7
D4-AJW3-55	13.97	6.99	D4-AJW3-180	45.72	12.7
D4-AJW3-60	15.24	7.62	D4-AJW3-190	48.26	12.7
D4-AJW3-65	16.51	8.89	D4-AJW3-200	50.80	12.7
D4-AJW3-70	17.78	8.89	D4-AJW3-210	53.34	12.7
D4-AJW3-75	19.05	9.5	D4-AJW3-220	55.88	12.7
D4-AJW3-80	20.32	10.16	D4-AJW3-230	58.42	12.7
D4-AJW3-85	21.59	10.16	D4-AJW3-240	60.96	12.7
D4-AJW3-90	22.86	12.7	D4-AJW3-250	63.50	12.7
D4-AJW3-95	24.13	12.7			
D4-AJW3-100	25.40	12.7			
D4-AJW3-110	27.94	12.7			

PART NUMBER	MATERIAL	FINISH
D4-AJW3-XX	CARBON STEEL	ZINC & CLEAR PASSIVATE
D4-AJW3-XX ZBB	CARBON STEEL	ZINC & BLACK PASSIVATE
D4-AJW3-XX QA	CARBON STEEL	CADMIUM PLATE
D4-AJW3-XX SS	STAINLESS STEEL	CLEAN

THIRD ANGLE PROJECTION		 CONNECT · CREATE · INNOVATE
MILLIMETERS [IN]		
TOLERANCES UNLESS OTHERWISE NOTED		DESCRIPTION
ALL DIMENSIONS WITHOUT TOLERANCES ARE FOR REFERENCE ONLY.		STANDARD LINE FASTENER SIZE 3 WING HEAD
PER ASME Y14.5M-1994		SIZE A3 SYSTEM NX DWG NO. J-D4-AJW3
DRAWN BY MJW DATE 22-01-08		SCALE 5:1 SHEET 1 OF 1

6

5

4

3

2

1