

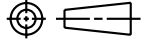

REV	DATE	DRAWN/CHKD	DESCRIPTION	PART NUMBER	MATERIAL	FINISH
			INITIAL DRAWING RELEASE	SEE TABLE 1		

MILLIMETERS

ALL DIMENSIONS WITHOUT TOLERANCES ARE FOR REFERENCE ONLY.

THIRD ANGLE PROJECTION A4 PAPER SIZE

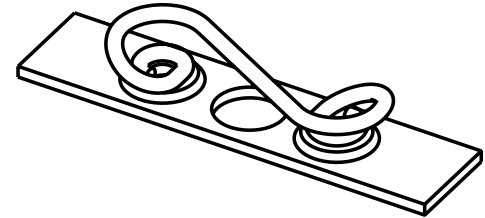
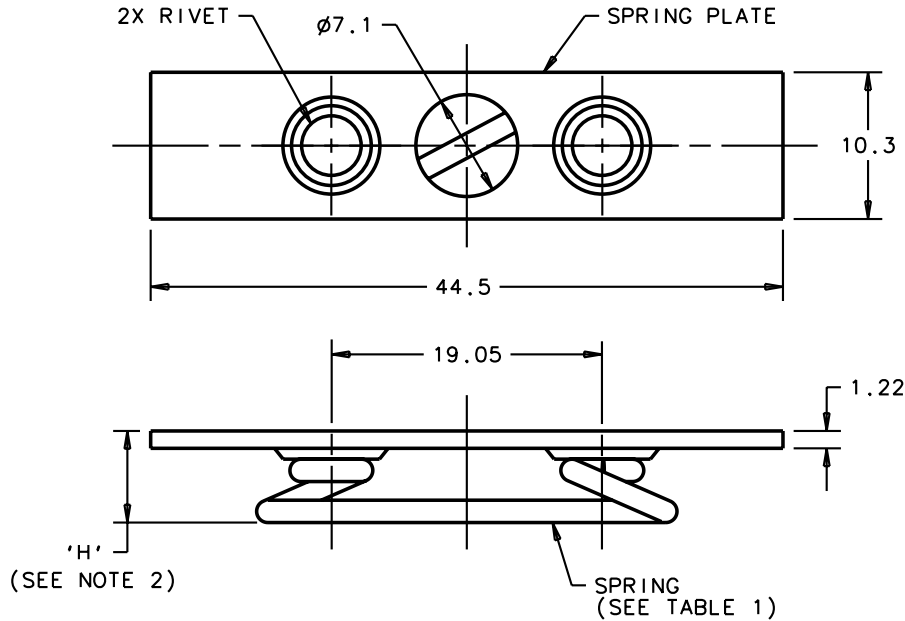

TABLE 1

ITEM	PART NUMBER			MATERIAL	FINISH
ASSEMBLY	D4-X485-250	D4-X485-275	D4-X485-300	--	--
SPRING PLATE	D4-X485-1	D4-X485-1	D4-X485-1	BRIGHT MILD STEEL	--
SPRING	D4-S4-175	D4-S4-200	D4-S4-225	HIGH TENSILE STEEL	ZINC PLATE BRIGHT CHROMATE
RIVET	DZUS 1069-2	DZUS 1069-2	DZUS 1069-2	--	--

TABLE 2

PART NO.	DIMENSION 'H'	
	MM	INCHES
D4-X485-250	6.35	.250
D4-X485-275	7.00	.275
D4-X485-300	7.62	.300