

6

5

4

3

2

1

DFCI	DZUS	SOUTHCO	MATERIAL	G	U
121J-320-SS	AJ3-20SS	D4-AJ3-20SSNA	303 STAINLESS STEEL	0.200	0.075
121J-320-Z3BT	AJ3-20ZBT	D4-AJ3-20ZBTNA	8620 STEEL	0.200	0.075
121J-320-Z3C	AJ3-20ZBC	D4-AJ3-20ZBCNA	8620 STEEL	0.200	0.075
121J-320-Z3Y	AJ3-20ZBY	D4-AJ3-20ZBYNA	8620 STEEL	0.200	0.075
121J-320-C3C	AJ3-20CBC	D4-AJ3-20CBCNA	8620 STEEL	0.200	0.075
121J-325-C3Y	AJ3-25CBY	D4-AJ3-25CBYNA	8620 STEEL	0.250	0.075
121J-325-SS	AJ3-25SS	D4-AJ3-25SSNA	303 STAINLESS STEEL	0.250	0.075
121J-325-SS-BOF	AJ3-25SSBA	D4-AJ3-25SSBANA	303 STAINLESS STEEL	0.250	0.075
121J-325-SS-PAS	AJ3-25SSPS	D4-AJ3-25SSPSNA	303 STAINLESS STEEL	0.250	0.075
121J-325-Z3B	AJ3-25ZBB	D4-AJ3-25ZBBNA	8620 STEEL	0.250	0.075
121J-325-Z3BT	AJ3-25ZBT	D4-AJ3-25ZBTNA	8620 STEEL	0.250	0.075
121J-325-Z3C	AJ3-25ZBC	D4-AJ3-25ZBCNA	8620 STEEL	0.250	0.075
121J-325-Z3CT	AJ3-25ZCT	D4-AJ3-25ZCTNA	8620 STEEL	0.250	0.075
121J-325-Z3Y	AJ3-25ZBY	D4-AJ3-25ZBYNA	8620 STEEL	0.250	0.075
121J-325-C3C	AJ3-25CBC	D4-AJ3-25CBCNA	8620 STEEL	0.250	0.075
121J-330B150-Z3C	AJ3-30B130ZBC	D4-AJ3-30B130ZBCNA	8620 STEEL	0.300	0.100
121J-330-C3C	AJ3-30CBC	D4-AJ3-30CBCNA	8620 STEEL	0.300	0.100
121J-330-C3Y	AJ3-30CBY	D4-AJ3-30CBYNA	8620 STEEL	0.300	0.100
121J-330-C5Y	AJ3-30C5Y	D4-AJ3-30CDYNA	8620 STEEL	0.300	0.100
121J-330-SS	AJ3-30SS	D4-AJ3-30SSNA	303 STAINLESS STEEL	0.300	0.100
121J-330-SS-PAS	AJ3-30SSPS	D4-AJ3-30SSPSNA	303 STAINLESS STEEL	0.300	0.100
121J-330T130-C3Y	AJ3-30T130CBY	D4-AJ3-30T130CBYNA	8620 STEEL	0.300	0.100
121J-330T130-Z3CT	AJ3-30T130ZCT	D4-AJ3-30T130ZCTNA	8620 STEEL	0.300	0.100
121J-330-Z3B	AJ3-30ZBB	D4-AJ3-30ZBBNA	8620 STEEL	0.300	0.100
121J-330-Z3C	AJ3-30ZBC	D4-AJ3-30ZBCNA	8620 STEEL	0.300	0.100
121J-330-Z3CT	AJ3-30ZCT	D4-AJ3-30ZCTNA	8620 STEEL	0.300	0.100
121J-330-Z3YT	AJ3-30ZYT	D4-AJ3-30ZYTNA	8620 STEEL	0.300	0.100
121J-335B175-Z3C	AJ3-35B175ZBC	D4-AJ3-35B175ZBCNA	8620 STEEL	0.350	0.150
121J-335-C3C	AJ3-35CBC	D4-AJ3-35CBCNA	8620 STEEL	0.350	0.150
121J-335-C3Y	AJ3-35CBY	D4-AJ3-35CBYNA	8620 STEEL	0.350	0.150
121J-335-SS	AJ3-35SS	D4-AJ3-35SSNA	303 STAINLESS STEEL	0.350	0.150
121J-335-Z3CT	AJ3-35ZCT	D4-AJ3-35ZCTNA	8620 STEEL	0.350	0.150
121J-335-Z5Y	AJ3-35Z5Y	D4-AJ3-35Z5YNA	8620 STEEL	0.350	0.150
121J-340-C3C	AJ3-40CBC	D4-AJ3-40CBCNA	8620 STEEL	0.400	0.200
121J-340-C3Y	AJ3-40CBY	D4-AJ3-40CBYNA	8620 STEEL	0.400	0.200
121J-340-SS	AJ3-40SS	D4-AJ3-40SSNA	303 STAINLESS STEEL	0.400	0.200
121J-340-Z3BT	AJ3-40ZBT	D4-AJ3-40ZBTNA	8620 STEEL	0.400	0.200
121J-340-Z3C	AJ3-40ZBC	D4-AJ3-40ZBCNA	8620 STEEL	0.400	0.200
121J-340-Z3CT	AJ3-40ZCT	D4-AJ3-40ZCTNA	8620 STEEL	0.400	0.200
121J-340-Z3YT	AJ3-40ZYT	D4-AJ3-40ZYTNA	8620 STEEL	0.400	0.200
121J-345-BOC	AJ3-45RB	D4-AJ3-45RBNA	8620 STEEL	0.450	0.225
121J-345-C3C	AJ3-45CBC	D4-AJ3-45CBCNA	8620 STEEL	0.450	0.225
121J-345-SS	AJ3-45SS	D4-AJ3-45SSNA	303 STAINLESS STEEL	0.450	0.225
121J-345-SS-PAS	AJ3-45SSPS	D4-AJ3-45SSPSNA	303 STAINLESS STEEL	0.450	0.225
121J-345-Z3C	AJ3-45ZBC	D4-AJ3-45ZBCNA	8620 STEEL	0.450	0.225
121J-345-Z3YT	AJ3-45ZYT	D4-AJ3-45ZYTNA	8620 STEEL	0.450	0.225
121J-350-C3C	AJ3-50CBC	D4-AJ3-50CBCNA	8620 STEEL	0.500	0.250
121J-350-K3C	AJ3-50KFC	D4-AJ3-50KFCNA	8620 STEEL	0.500	0.250
121J-350-SS	AJ3-50SS	D4-AJ3-50SSNA	303 STAINLESS STEEL	0.500	0.250
121J-350-Z3C	AJ3-50ZBC	D4-AJ3-50ZBCNA	8620 STEEL	0.500	0.250
121J-355-Z3C	AJ3-55ZBC	D4-AJ3-55ZBCNA	8620 STEEL	0.550	0.275
121J-360-C3C	AJ3-60CBC	D4-AJ3-60CBCNA	8620 STEEL	0.600	0.300
121J-370-C3C	AJ3-70CBC	D4-AJ3-70CBCNA	8620 STEEL	0.700	0.350
121J-370-Z3B	AJ3-70ZBB	D4-AJ3-70ZBBNA	8620 STEEL	0.700	0.350
121J-370-Z3BT	AJ3-70ZBT	D4-AJ3-70ZBTNA	8620 STEEL	0.700	0.350
121J-370-Z3C	AJ3-70ZBC	D4-AJ3-70ZBCNA	8620 STEEL	0.700	0.350
121J-380-SS	AJ3-80SS	D4-AJ3-80SSNA	303 STAINLESS STEEL	0.800	0.400
121J-380-Z3CT	AJ3-80ZCT	D4-AJ3-80ZCTNA	8620 STEEL	0.800	0.400
121J-380-C3C	AJ3-80CBC	D4-AJ3-80CBCNA	8620 STEEL	0.800	0.400
121J-390-C3C	AJ3-90CBC	D4-AJ3-90CBCNA	8620 STEEL	0.900	0.500
121J-3100-C3C	AJ3-100CBC	D4-AJ3-100CBCNA	8620 STEEL	1.000	0.500

REVISION HISTORY			
REV	DATE	BY	DESCRIPTION
B	21MAR2018	NSB/VK	PRN: P2018-0716

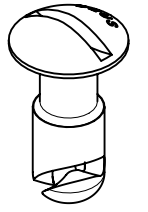

SCALE 2:1

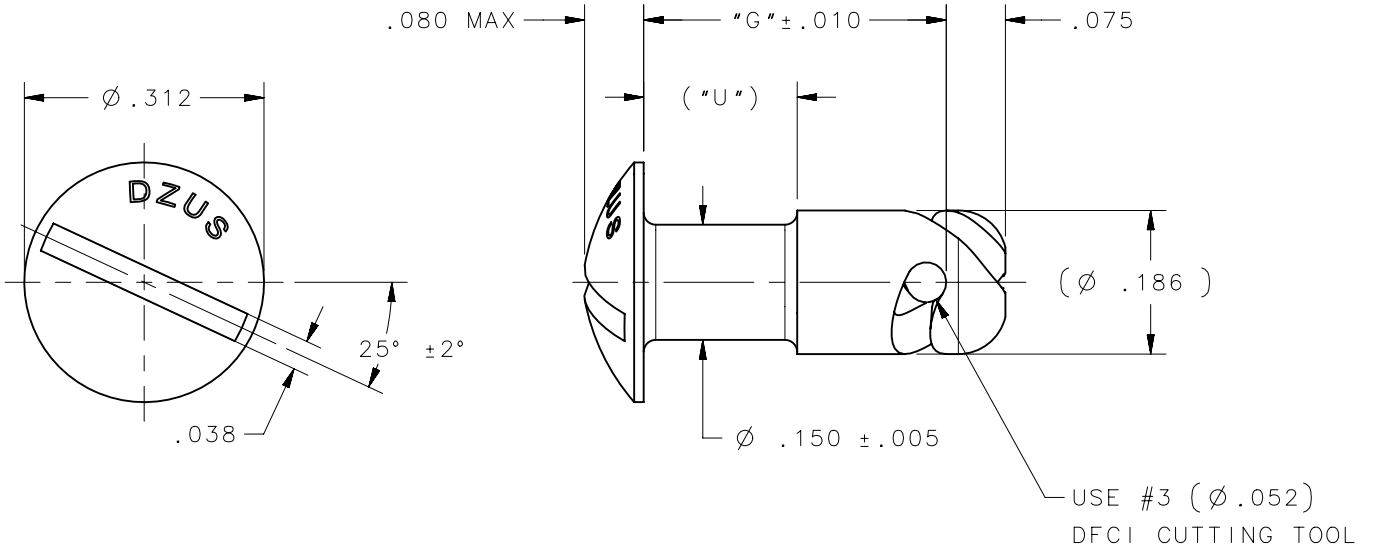

D4-AJ3-XXYYYYNA

XX= LENGTH
SEE TABLE

REFER TO NOTE 3 FOR
OTHER FINISH OPTIONS
EX. D4-AJ3-70ZCTNA

- NOTES:
1. REMOVE ALL BURRS AND BREAK SHARP CORNERS.
 2. ALL CORNERS AND FILLETS R.005 MAX.
 3. SEE J-D5-0-3 FOR FINISH SUFFIXES AND SPECIFICATIONS.

THIRD ANGLE PROJECTION				
INCHES [MM]		DESCRIPTION		
TOLERANCES UNLESS OTHERWISE NOTED		OVAL HEAD STUD		
X°	±2°	SIZE	SYSTEM	DWG NO.
X/X	±1/32	B	NX	J-D4-AJ3NA
.XX	±.015	DRAWN BY		
.XXX	±.010	CMS/NJF		
PER ASME Y14.5M-1994		DATE	SCALE	SHEET
		04MAY2015	4:1	1 OF 1

6

5

4

3

2

1