

PROPRIETARY ITEM  
 EXCEPT FOR USES EXPRESSLY GRANTED  
 IN WRITING, INFORMATION DISCLOSED  
 HEREON IS CONFIDENTIAL AND ALL  
 RIGHTS, PATENT AND OTHERWISE,  
 ARE RESERVED BY SOUTHCO, INC.

REVISION HISTORY				
REV	DATE	DRAWN	CHECKED	DESCRIPTION
				INITIAL DRAWING RELEASE

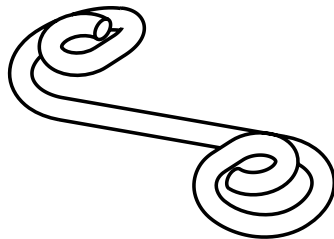
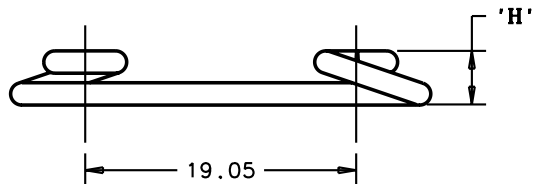
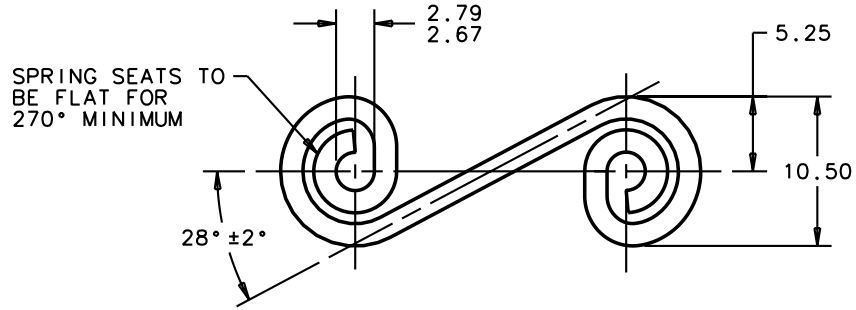

ISOMETRIC VIEW

PART NUMBER	METRIC	INCHES	MATERIAL	FINISH	FORM
	'H'				
D4-S4-300	7.62	0.300	HIGH TENSILE STEEL	ZINC PLATE BRIGHT CHROMATE	ø1.57 (.062) WIRE
D4-S4-275	6.98	0.275			
D4-S4-250	6.35	0.250			
D4-S4-225	5.72	0.225			
D4-S4-200	5.08	0.200			
D4-S4-175	4.45	0.175			
D4-S4-150	3.81	0.150			
PART NUMBER	METRIC	INCHES	MATERIAL	FINISH	FORM
	'H'				
D4-S4-275SS	6.98	0.275	STAINLESS STEEL	PASSIVATE	ø1.57 (.062) WIRE
D4-S4-250SS	6.35	0.250			
D4-S4-225SS	5.72	0.225			
D4-S4-200SS	5.08	0.200			
D4-S4-175SS	4.45	0.175			
D4-S4-150SS	3.81	0.150			
PART NUMBER	METRIC	INCHES	MATERIAL	FINISH	FORM
	'H'				

THIRD ANGLE PROJECTION

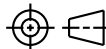

ALL DIMENSIONS WITHOUT TOLERANCES ARE FOR REFERENCE ONLY.

MILLIMETERS [IN]

VOLUME XXXXmm<sup>3</sup> MASS XXXXg

**southco**<sup>®</sup>  
 CONNECT · CREATE · INNOVATE

TITLE  
**SPRING TYPE S4**

SIZE SYSTEM DWG NO  
 A4 I-DEAS J-D4-S4

DRWN/CHKD DATE SCALE SHEET  
 CW/MJS 07JAN2008 2:1 1 OF 1