



D4 DZUS® Standard Line Quarter-Turn Fasteners

Stud selection · Size 3

Material and Finish

Studs:
Steel, zinc plated or stainless steel

82

85

D8

D9

D1

D4

D5

D7

NY

To select correct fastener:

1. Select receptacle

Choose a receptacle from page 415

2. Select retainer and accessories

from page 416 and note any adjustment values

3. Specify stud length

Calculate the total material thickness (TMT) using the formula given for the receptacle selected. Find the range of TMT using the stud length selection table (right) using the column (A or B) given for the receptacle selected.

4. Complete the stud part number

by specifying the head style **H**, stud length **K**, and material **M**

Example: For rivet-on D4-S3-175 use column A

For TMT value calculated as 5.2 (.206), K = 35

For slotted head style in steel material, completed part number: D4-AJ3-35

A complete example can be found on page 377.

Notes

Stainless steel material may require a higher minimum order quantity. Contact Southco for details.

H Head Styles - Tool Actuated

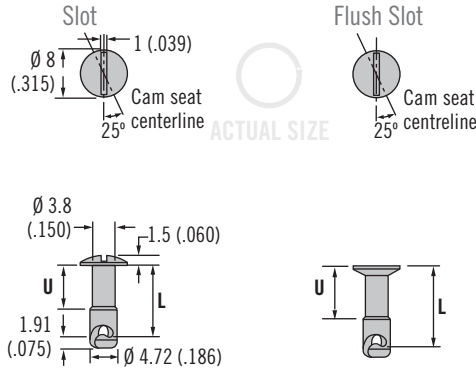

H Head Styles - Hand Actuated

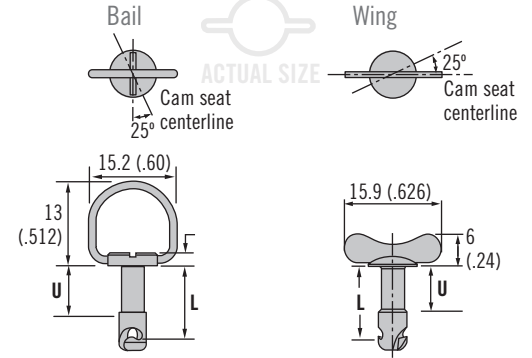

Flush

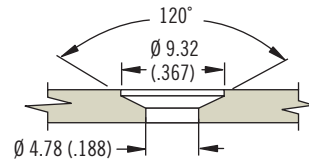

Standard

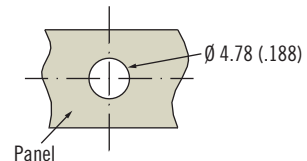

- H** Head style
- AJ Slot
- AJW Wing head
- BJR Bail
- FJ Flush slot

- K** Length
Enter number from selection table below
- M** Material
SS Stainless steel
Omit for steel, zinc plated

D4 - H 3 - K M

Stud Length Table										
A				B				K	U	L
TMT Range For: Rivet-On Receptacle D4-S3-175		TMT Range For: Rivet-On Receptacle D4-S3-150		TMT Range For: Weld-On Receptacle D4-X735-205		TMT Range For: Weld-On Receptacle D4-X735-180				
Min.	Max.	Min.	Max.	Min.	Max.	Min.	Max.			
2.41 (.095)	3.02 (.119)	3.05 (.12)	3.66 (.144)	1.65 (.065)	2.26 (.089)	2.29 (.09)	2.9 (.114)	25	1.91 (.075)	6.35 (.250)
3.68 (.145)	4.29 (.169)	4.32 (.17)	4.93 (.194)	2.92 (.115)	3.53 (.139)	3.56 (.14)	4.17 (.164)	30	2.54 (.100)	7.62 (.300)
4.95 (.195)	5.56 (.219)	5.59 (.22)	6.2 (.244)	4.19 (.165)	4.8 (.189)	4.83 (.19)	5.44 (.214)	35	3.81 (.150)	8.89 (.350)
6.22 (.245)	6.83 (.269)	6.86 (.27)	7.47 (.294)	5.46 (.215)	6.07 (.239)	6.1 (.24)	6.71 (.264)	40	5.08 (.200)	10.16 (.400)
7.49 (.295)	8.1 (.319)	8.13 (.32)	8.74 (.344)	6.73 (.265)	7.34 (.289)	7.37 (.29)	7.98 (.314)	45	5.77 (.225)	11.43 (.450)
8.76 (.345)	9.37 (.369)	9.4 (.37)	10.01 (.394)	8.00 (.315)	8.61 (.339)	8.64 (.34)	9.25 (.364)	50	6.35 (.250)	12.70 (.500)
10.03 (.395)	10.64 (.419)	10.67 (.42)	11.28 (.444)	9.27 (.365)	9.88 (.389)	9.91 (.39)	10.52 (.414)	55	6.99 (.275)	13.97 (.550)
11.3 (.445)	11.91 (.469)	11.94 (.47)	12.55 (.494)	10.54 (.415)	11.15 (.439)	11.18 (.44)	11.79 (.464)	60	7.62 (.300)	15.24 (.600)
12.57 (.495)	13.18 (.519)	13.21 (.52)	13.82 (.544)	11.81 (.465)	12.42 (.489)	12.45 (.49)	13.06 (.514)	65	8.89 (.350)	16.51 (.650)
13.84 (.545)	14.45 (.569)	14.48 (.57)	15.09 (.594)	13.08 (.515)	13.69 (.539)	13.72 (.54)	14.33 (.564)	70		17.78 (.700)
15.11 (.595)	15.72 (.619)	15.75 (.62)	16.36 (.644)	14.35 (.565)	14.96 (.589)	14.99 (.59)	15.6 (.614)	75	9.5 (.375)	19.05 (.750)
16.38 (.645)	16.99 (.669)	17.02 (.67)	17.63 (.694)	15.62 (.615)	16.23 (.639)	16.26 (.64)	16.87 (.664)	80	10.16 (.400)	20.32 (.800)



www.southco.com/D4

Dimensions in millimeters (inch) unless otherwise stated



D4 *DZUS*® Standard Line Quarter-Turn Fasteners

Receptacles · Size 3

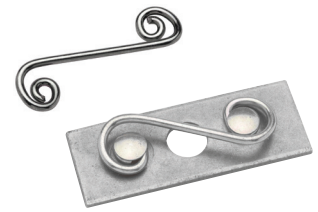

Rivet-On

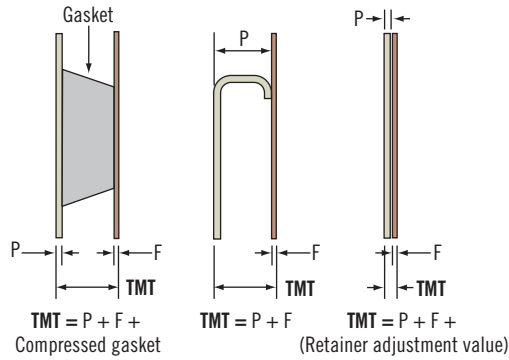
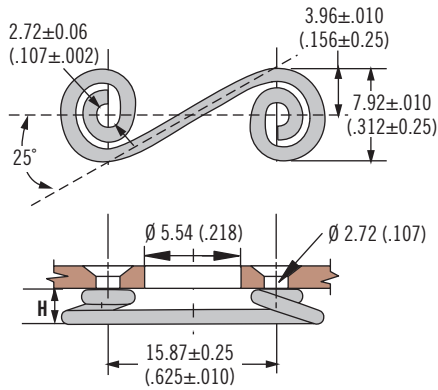

Part Number		H±0.25(.010)	Stud Selection Column
Steel	Stainless Steel		
D4-S3-150	D4-S3-150SS	3.81 (.150)	A
D4-S3-175	D4-S3-175SS	4.45 (.175)	

Material and Finish

Steel, zinc plated or stainless steel

Notes

After selecting receptacle use stud selection letter **A** and follow instruction on page 414

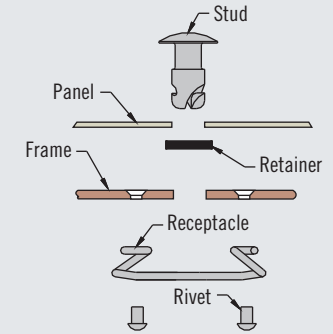

Part Number

See table

Weld-On

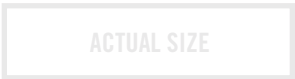
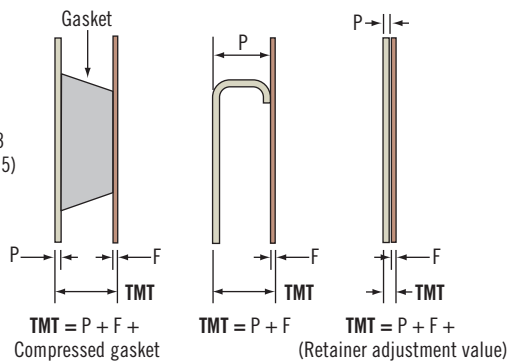
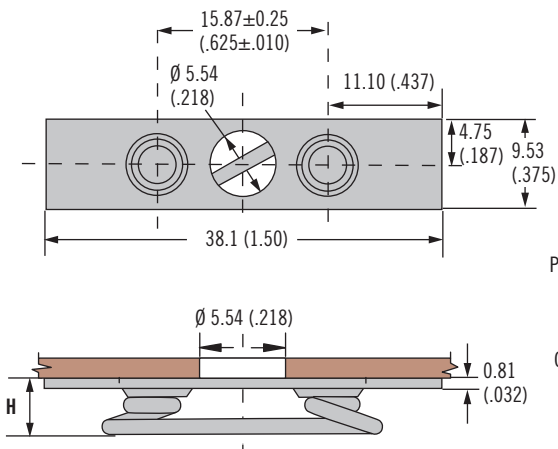

Part Number	H	Stud Selection Column
D4-X735-180	4.57 (.180)	B
D4-X735-205	5.21 (.205)	

Material and Finish

Steel, zinc plated

Notes

After selecting receptacle use stud selection letter **B** and follow instruction on page 414

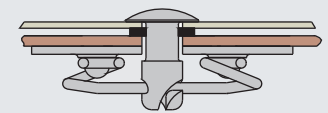

Part Number

See table



D4 DZUS® Standard Line Quarter-Turn Fasteners

Retainers · Size 3, 4, 5 and 6

Material and Finish

Retaining ring: Steel, zinc plated

Retaining spring: Stainless steel

Retainer GH: Aluminum, natural

Retainer GP, natural: HD Polythene

Retainer GP, black: Polypropylene

Installation Notes

1. Place the retainer on the mandrel as shown
2. Align ring or spring ends so that they will miss the stud cam
3. Place mandrel in end of stud cam
4. Place tool over mandrel
5. Push retainer until it is sealed in stud undercut

Notes

Tooling:

29 - TFRS hand tool: Spreads the inside diameter of retainers over stud shanks and then pushes them into stud undercuts.

29 - TB1A block: Nests stud heads during installation. (Any flat block may be used for BJR bail head studs).

Part Number

See table

Retainer GP

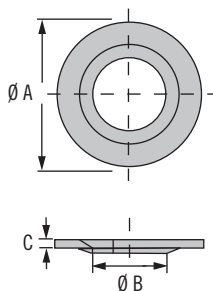

Retainer GH

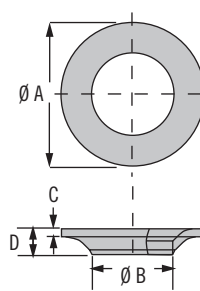

Retaining Ring

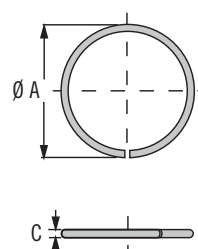

Install Retainer GP, Retaining Ring and SX

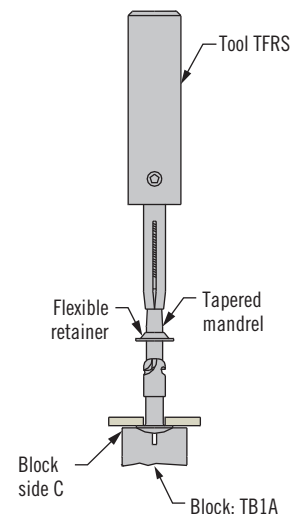

Install Retainer GH

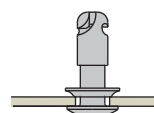
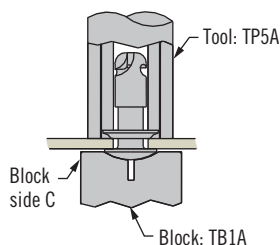

Standard Hole
Small diameter faces panel

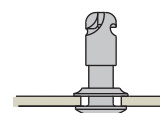

Oversized Hole
Large diameter faces panel

Retaining Spring

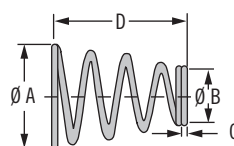

Size	Type	Part Number	Ø A	Ø B	C	D	Adjustment Value	Installation Tool Part Number
3	Retainer GP, natural	D4-GP3	7.9 (.311)	4.06 (.160)	0.5 (.020)	N/A	Add 0.51 (.020)	29-TFRS3 and 29-TB1A3
	Retainer GP, black	D4-GP3B						
	Retainer GH	D4-GH3	4.8 (.188)	0.38 (.015)	1.3 (.051)	Add 0.38 (.015)	29-TP5A3 and 29-TB1A3	
	Retaining ring	D4-RR3	5.3 (.209)	N/A	0.56 (.022)	N/A	Add 0.56 (.022)	29-TFRS3 and 29-TB1A3
Retaining spring	D4-SX520	7.9 (.311)	3.8 (.149)	0.46 (.018)	17.5 (.689)	Add 0.91 (.036)		
4	Retainer GP, natural	D4-GP4	11.1 (.437)	5.4 (.21)	0.7 (.028)	N/A	Add 0.7 (.028)	29-TFRS4 and 29-TB1A4
	Retainer GP, black	D4-GP4B						
	Retainer GH	D4-GH4	6.35 (.250)	0.64 (.025)	2.1 (.083)	Add 0.64 (.025)	29-TP5A4 and 29-TB1A4	
	Retaining ring	D4-RR4	7.1 (.280)	N/A	0.71 (.028)	N/A	Add 0.74 (.029)	29-TFRS4 and 29-TB1A4
Retaining spring	D4-SX523	11.1 (.437)	5.1 (.200)	0.64 (.025)	17.5 (.689)	Add 1.28 (.050)		
5	Retainer GP, natural	D4-GP5	14.3 (.562)	6.5 (.256)	0.83 (.033)	N/A	Add 0.86 (.034)	29-TFRS5 and 29-TB1A5
	Retainer GP, black	D4-GP5B						
	Retainer GH	D4-GH5	7.9 (.311)	0.88 (.035)	2.7 (.106)	Add 0.78 (.031)	29-TP5A5 and 29-TB1A5	
	Retaining ring	D4-RR5	8.92 (.351)	N/A	0.91 (.036)	N/A	Add 0.91 (.035)	29-TFRS5 and 29-TB1A5
Retaining spring	D4-SX510	14.3 (.562)	6.5 (.256)	0.82 (.032)	19 (.748)	Add 1.64 (.064)		
6	Retainer GH	D4-GH6	15.9 (.625)	9.5 (.374)	0.88 (.035)	2.9 (.114)	Add .88 (.035)	29-TP5A6 and 29-TB1A6
	Retaining ring	D4-RR6	10.78 (.424)	N/A	1.14 (.045)	N/A	Add 1.14 (.045)	29-TFRS6 and 29-TB1A6
	Retaining spring	D4-SX518	15.9 (.625)	8 (.315)	0.88 (.035)	19 (.748)	Add 1.76 (.070)	

Dimensions in millimeters (inch) unless otherwise stated

DZUS®

southco®
CONNECT · CREATE · INNOVATE



www.southco.com/D4

D4 DZUS® Standard Line Quarter-Turn Fasteners

Retainers · Size 3, 4, 5 and 6



Retainer GA

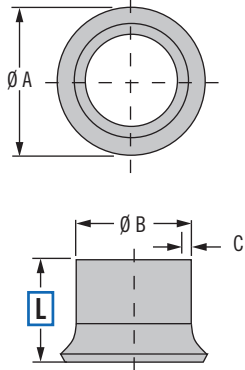

Installation Retainer GA

1.



2.

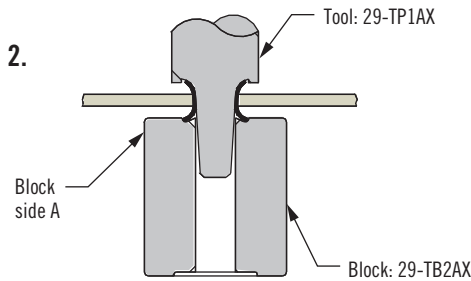

3.

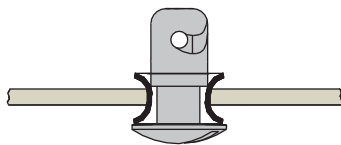

4.

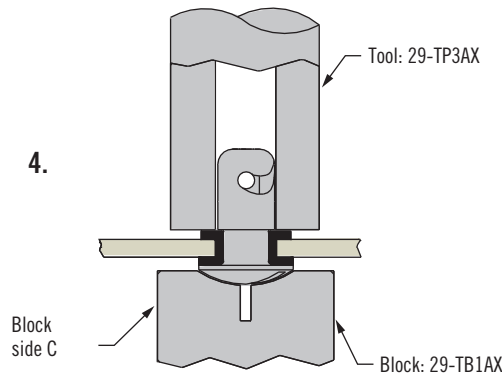

Size	Panel Thickness	L	Part Number	Ø A	Ø B	C	Adjustment Formula	Installation Tool Part Number
3	0.38 - 0.64 (.015 - .025)	4.45 (.175)	D4-GA3-175	Ø 7.9 (.311)	5.6 (.220)	0.38 (.015)	Add 0.38 (.015)	29-TP1A3, 29-TP3A3, 29-TB1A3 and 29-TB2A3 (all required)
	0.66 - 1.27 (.026 - .050)	5.08 (.200)	D4-GA3-200					
	1.29 - 2.38 (.051 - .094)	6.35 (.250)	D4-GA3-250					
4	0.38 - 0.64 (.015 - .025)	4.45 (.175)	D4-GA4-175	10.3 (.405)	7.9 (.311)	1.28 (.050)	Add 1.28 (.050)	29-TP1A4, 29-TP3A4 and 29-TB1A4 (all required)
	0.66 - 1.27 (.026 - .050)	5.08 (.200)	D4-GA4-200					
	1.29 - 2.38 (.051 - .094)	6.35 (.250)	D4-GA4-250					
5	0.38 - 0.64 (.015 - .025)	4.45 (.175)	D4-GA5-175	12.7 (.500)	9.5 (.374)	1.42 (.056)	Add 1.42 (.056)	29-TP1A5, 29-TP3A5, 29-TB1A5 and 29-TB2A5 (all required)
	0.66 - 1.27 (.026 - .050)	5.08 (.200)	D4-GA5-200					
	1.29 - 2.38 (.051 - .094)	6.35 (.250)	D4-GA5-250					
6	0.38 - 0.64 (.015 - .025)	4.45 (.175)	D4-GA6-175	15.1 (.594)	11.1 (.437)	1.42 (.056)	Add 1.42 (.056)	29-TP1A6, 29-TP3A6, 29-TB1A6 and 29-TB2A6 (all required)
	0.66 - 1.27 (.026 - .050)	5.08 (.200)	D4-GA6-200					
	1.29 - 2.38 (.051 - .094)	6.35 (.250)	D4-GA6-250					

Material and Finish

Retainer GA: Aluminum, natural

Installation Notes

1. Insert retainer in panel hole
2. Set retainer
3. Insert stud
4. Flatten retainer

82

85

D8

D9

D1

D4

D5

D7

NY





D4 DZUS® Standard Line Quarter-Turn Fasteners

Stud selection · Size 4

Material and Finish

Studs:

Steel, zinc plated or stainless steel

82

85

D8

D9

D1

D4

D5

D7

NY

To select correct fastener:

1. Select receptacle

Choose a receptacle from pages 420-421

2. Select retainer and accessories

from pages 416-417 and note any adjustment values

3. Specify stud length

Calculate the total material thickness (TMT) using the formula given for the receptacle selected. Find the range of TMT using the stud length selection table (right) using the column (A, B, C, or D) given for the receptacle selected.

4. Complete the stud part number

by specifying the head style **[H]**, stud length **[K]**, and material **[M]**

Example:

For rivet-on

D4-S4-225 use column A

For TMT value calculated as 5.2 (.206), K = 40

For slotted head style in steel material, completed part number: D4-AJ4-40

A complete example can be found on page 377

[H] Head Styles - Tool Actuated

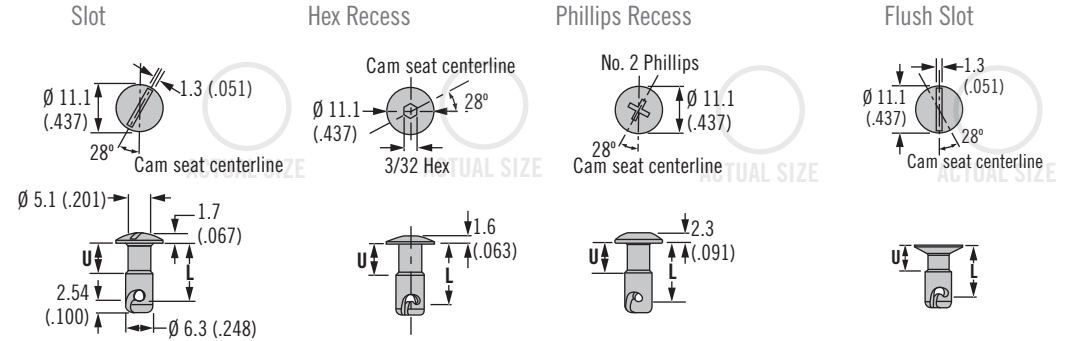

[H] Head Styles - Hand Actuated

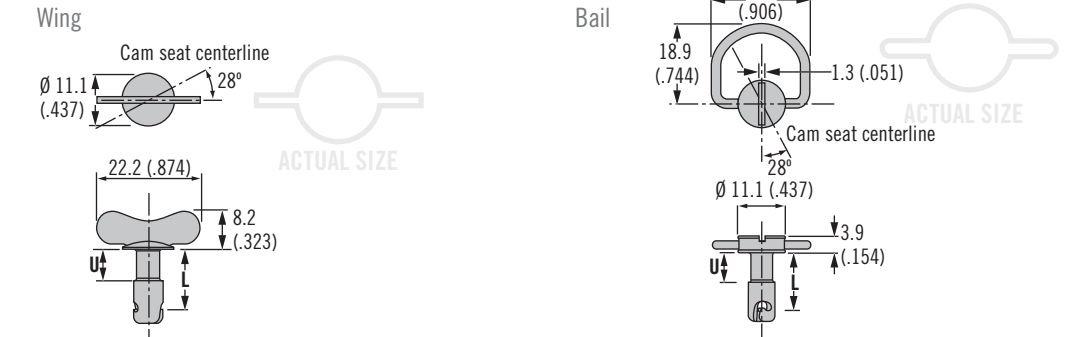

Stud Length Table										
A				B				K	U	L
TMT Range For: Rivet-On Receptacle D4-S4-225		TMT Range For: Rivet-On Receptacle D4-S4-200		TMT Range For: Weld-On Receptacle D4-X485-300		TMT Range For: Weld-On Receptacle D4-X485-275				
Min.	Max.	Min.	Max.	Min.	Max.	Min.	Max.			
1.27 (.050)	1.88 (.074)	1.91 (.075)	2.51 (.099)	~	~	~	~	25	1.91 (.075)	6.35 (.250)
2.54 (.100)	3.15 (.124)	3.18 (.125)	3.78 (.149)	0.64 (.025)	1.24 (.049)	1.27 (.050)	1.88 (.074)	30	2.54 (.100)	7.62 (.300)
3.81 (.150)	4.42 (.174)	4.45 (.175)	5.05 (.199)	1.91 (.075)	2.51 (.099)	2.54 (.100)	3.15 (.124)	35	3.81 (.150)	8.89 (.350)
5.08 (.200)	5.69 (.224)	5.72 (.225)	6.32 (.249)	3.18 (.125)	3.78 (.149)	3.81 (.150)	4.42 (.174)	40	5.08 (.200)	10.16 (.400)
6.35 (.250)	6.96 (.274)	6.99 (.275)	7.59 (.299)	4.45 (.175)	5.05 (.199)	5.08 (.200)	5.69 (.224)	45	5.72 (.225)	11.43 (.450)
7.62 (.300)	8.23 (.324)	8.26 (.325)	8.86 (.349)	5.72 (.225)	6.32 (.249)	6.35 (.250)	6.96 (.274)	50	6.35 (.250)	12.70 (.500)
8.89 (.350)	9.50 (.374)	9.53 (.375)	10.13 (.399)	6.99 (.275)	7.59 (.299)	7.62 (.300)	8.23 (.324)	55	6.99 (.275)	13.97 (.550)
10.16 (.400)	10.77 (.424)	10.80 (.425)	11.40 (.449)	8.26 (.325)	8.86 (.349)	8.89 (.350)	9.50 (.374)	60	7.62 (.300)	15.24 (.600)
11.43 (.450)	12.04 (.474)	12.07 (.475)	12.67 (.499)	9.53 (.375)	10.13 (.399)	10.16 (.400)	10.77 (.424)	65	8.89 (.350)	16.51 (.650)
12.70 (.500)	13.31 (.524)	13.34 (.525)	13.94 (.549)	10.80 (.425)	11.40 (.449)	11.43 (.450)	12.04 (.474)	70		17.78 (.700)
13.97 (.550)	14.58 (.574)	14.61 (.575)	15.21 (.599)	12.07 (.475)	12.67 (.499)	12.70 (.500)	13.31 (.524)	75	10.16 (.400)	19.05 (.750)
15.24 (.600)	15.85 (.624)	15.88 (.625)	16.48 (.649)	13.34 (.525)	13.94 (.549)	13.97 (.550)	14.58 (.574)	80		20.32 (.800)
16.51 (.650)	17.12 (.674)	17.15 (.675)	17.75 (.699)	14.61 (.575)	15.21 (.599)	15.24 (.600)	15.85 (.624)	85	12.70 (.500)	21.59 (.850)
17.78 (.700)	18.39 (.724)	18.42 (.725)	19.02 (.749)	15.88 (.625)	16.48 (.649)	16.51 (.650)	17.12 (.674)	90		22.86 (.900)
19.05 (.750)	19.66 (.774)	19.69 (.775)	20.29 (.799)	17.15 (.675)	17.75 (.699)	17.78 (.700)	18.39 (.724)	95	15.24 (.600)	24.13 (.950)
20.32 (.800)	20.93 (.824)	20.96 (.825)	21.56 (.849)	18.42 (.725)	19.02 (.749)	19.05 (.750)	19.66 (.774)	100		25.40 (1.00)



Flush

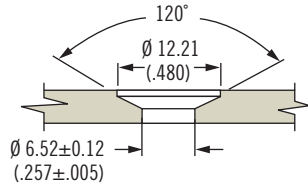

Standard

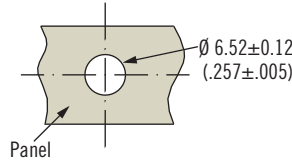

Part Number Selection

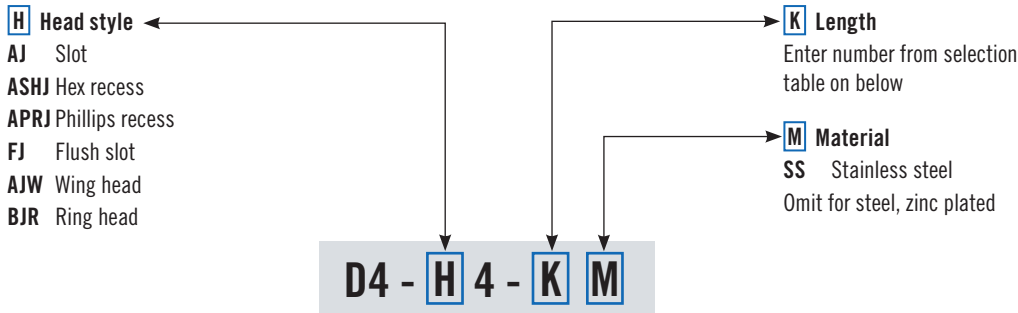

Stud Length Table						
C				K	U	L
TMT Range For: Clip-On Receptacle D4-SL4-305		TMT Range For: Clip-On Receptacle D4-SL4-280				
Min.	Max.	Min.	Max.			
~	~	~	~	25	1.91 (.075)	6.35 (.250)
~	~	1.17 (.046)	1.78 (.070)	30	2.54 (.100)	7.62 (.300)
1.80 (.071)	2.41 (.095)	2.44 (.096)	3.05 (.120)	35	3.81 (.150)	8.89 (.350)
3.07 (.121)	3.68 (.145)	3.71 (.146)	4.32 (.170)	40	5.08 (.200)	10.16 (.400)
4.34 (.171)	4.95 (.195)	4.98 (.196)	5.59 (.220)	45	5.72 (.225)	11.43 (.450)
5.61 (.221)	6.22 (.245)	6.25 (.246)	6.86 (.270)	50	6.35 (.250)	12.70 (.500)
6.88 (.271)	7.49 (.295)	7.52 (.296)	8.13 (.320)	55	6.99 (.275)	13.97 (.550)
8.15 (.321)	8.76 (.345)	8.79 (.346)	9.40 (.370)	60	7.62 (.300)	15.24 (.600)
9.42 (.371)	10.03 (.395)	10.06 (.396)	10.67 (.420)	65	8.89 (.350)	16.51 (.650)
10.69 (.421)	11.30 (.445)	11.33 (.446)	11.94 (.470)	70		17.78 (.700)
11.96 (.471)	12.57 (.495)	12.60 (.496)	13.21 (.520)	75	10.16 (.400)	19.05 (.750)
13.23 (.521)	13.84 (.545)	13.87 (.546)	14.48 (.570)	80		20.32 (.800)
14.50 (.571)	15.11 (.595)	15.14 (.596)	15.75 (.620)	85		12.7 (.500)
15.77 (.621)	16.38 (.645)	16.41 (.646)	17.02 (.670)	90	15.24 (.600)	22.86 (.900)
17.04 (.671)	17.65 (.695)	17.68 (.696)	18.29 (.720)	95		24.13 (.950)
18.31 (.721)	18.92 (.745)	18.95 (.746)	19.56 (.770)	100		25.40 (1.00)

Stud Length Table					
D			K	U	L
TMT Range For: Snap-In - Rear Mount Receptacle D4-SQC4-F					
Min.	Max.	D4-GP4B			
0.48 (.019)	1.09 (.043)	None	45	5.72 (.225)	11.43 (.450)
1.12 (.044)	1.73 (.068)	One	50	6.35 (.250)	12.70 (.500)
1.75 (.069)	2.36 (.093)	None	50		
2.39 (.094)	3.00 (.118)	One	55	6.99 (.275)	13.97 (.550)
3.02 (.119)	3.63 (.143)	None	55		
3.66 (.144)	4.27 (.168)	One	60	7.62 (.300)	15.24 (.600)
4.29 (.169)	4.90 (.193)	None	60		
4.93 (.194)	5.54 (.218)	One	65	8.89 (.350)	16.51 (.650)
5.56 (.219)	6.17 (.243)	None	65		
6.20 (.244)	6.81 (.268)	One	70		
6.83 (.269)	7.44 (.293)	None	70	10.16 (.400)	17.78 (.700)
7.47 (.294)	8.08 (.318)	One	75		
8.10 (.319)	8.71 (.343)	None	75	10.16 (.400)	19.05 (.750)
8.74 (.344)	9.35 (.368)	One	80		
9.37 (.369)	9.98 (.393)	None	80		

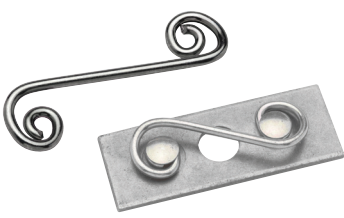

D4 DZUS® Standard Line Quarter-Turn Fasteners

Receptacles · Size 4

Material and Finish

Steel, zinc plated or stainless steel

Notes

After selecting receptacle use stud selection letter **A** and follow instruction on page 418

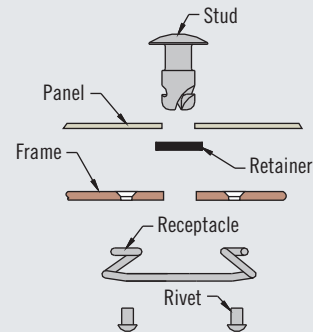

Part Number

See table

Utilize stud selection column indicated when choosing a stud length from the stud length table on page 418-419

Rivet-On

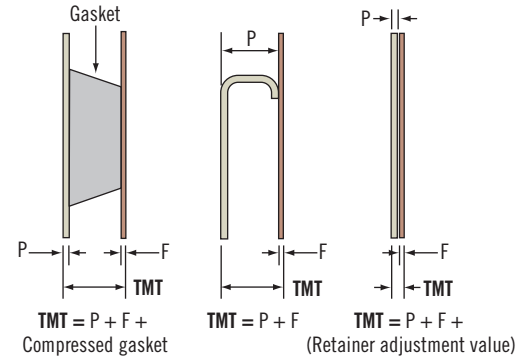
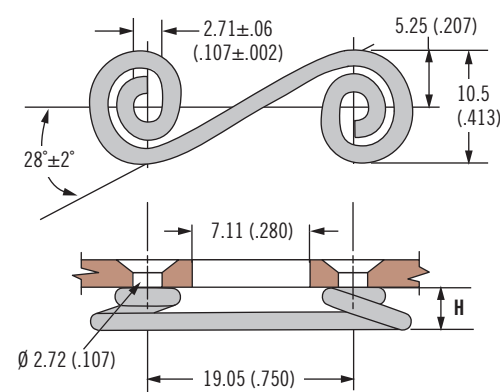

Part Number		H	Stud Selection Column
Steel	Stainless Steel		
D4-S4-200	D4-S4-200SS	5.08 (.200)	A
D4-S4-225	D4-S4-225SS	5.72 (.225)	

Material and Finish

Steel, zinc plated or stainless steel

Notes

After selecting receptacle use stud selection letter **B** and follow instruction on page 418

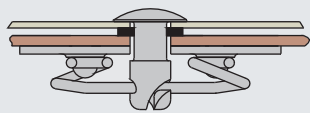

Weld-On

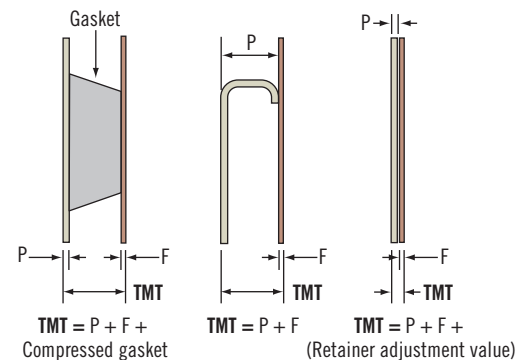
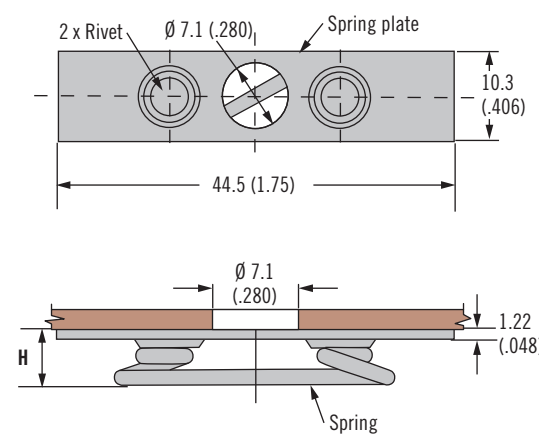

Part Number		H	Stud Selection Column
Steel	Stainless Steel		
D4-X485-275	D4-X485-275SS	6.98 (.275)	B
D4-X485-300	D4-X485-300SS	7.62 (.300)	

Part Number

See table

Utilize stud selection column indicated when choosing a stud length from the stud length table on page 418-419

Dimensions in millimeters (inch) unless otherwise stated

D4 DZUS® Standard Line Quarter-Turn Fasteners

Receptacles · Size 4



Clip-On

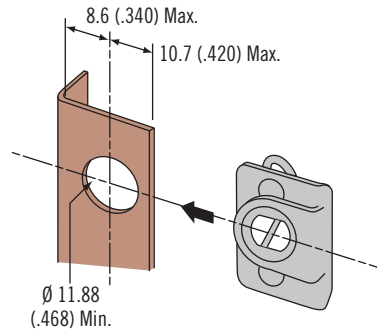
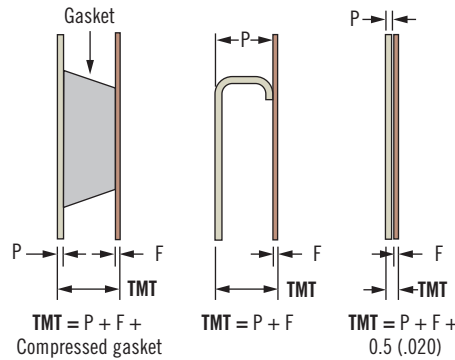
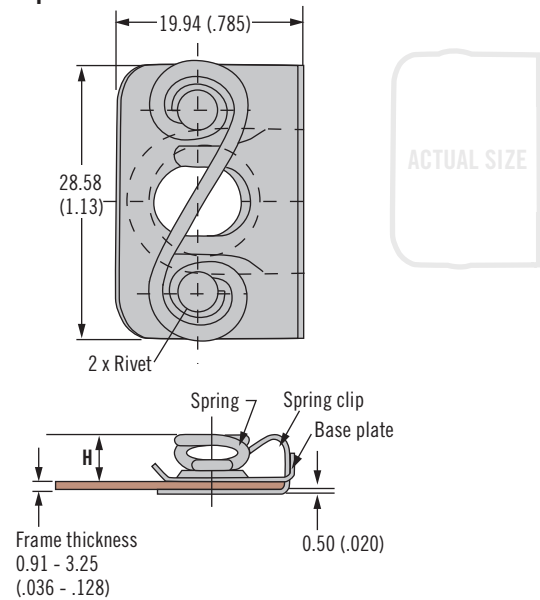

Part Number	H	Stud Selection Column
D4-SL4-280	7.11 (.280)	C
D4-SL4-305	7.75 (.305)	

Material and Finish

Steel, zinc plated

Notes

After selecting receptacle use stud selection letter **C** and follow instruction on page 418

Part Number

See table

Utilize stud selection column indicated when choosing a stud length from the stud length table on pages 418-419

Snap-In – Rear Mount

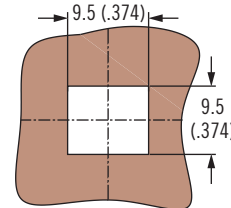
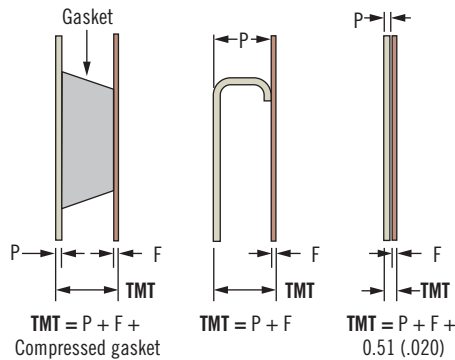
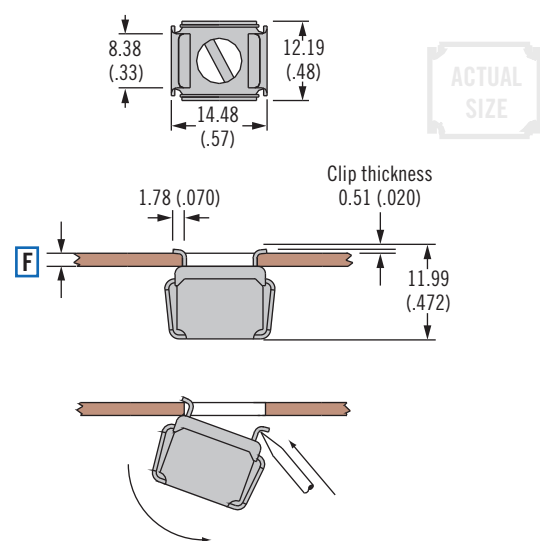

Part Number	F Frame Thickness	H	Stud Selection Column
D4-SQC4-16	0.78 - 1.42 (.031 - .056)	11.48 (.452)	D
D4-SQC4-20	1.47 - 1.98 (.058 - .078)	11.48 (.452)	
D4-SQC4-25	2 - 2.49 (.079 - .098)	11.48 (.452)	
D4-SQC4-30	2.59 - 3.18 (.102 - .125)	11.48 (.452)	

Material and Finish

Steel, zinc plated

Installation Notes

For stud retention use only retaining ring part number: D4-RR4

Notes

After selecting receptacle use stud selection letter **D** and follow instruction on page 418

Part Number

See table

Utilize stud selection column indicated when choosing a stud length from the stud length table on page 418-419





D4 DZUS® Standard Line Quarter-Turn Fasteners

Stud selection · Size 5

Material and Finish

Studs:
Steel, zinc plated or stainless steel

82

85

D8

D9

D1

D4

D5

D7

NY

To select correct fastener:

1. Select receptacle

Choose a receptacle from pages 424-425

2. Select retainer and accessories

from pages 416-417 and note any adjustment values

3. Specify stud length

Calculate the total material thickness (TMT) using the formula given for the receptacle selected. Find the range of TMT using the stud length selection table (right) using the column (A, B or C) given for the receptacle selected.

4. Complete the stud part number

by specifying the head style **H**, stud length **K**, and material **M**

Example:

For rivet-on

D4-S5-225 use column A

For TMT value calculated as 5.21 (.205), K = 40

For slotted head style in steel material, completed part number: D4-AJ5-40

A complete example can be found on page 377.

Notes

Stainless steel material may require a higher minimum order quantity. Contact Southco for details.

H Head Styles - Tool Actuated

Slot

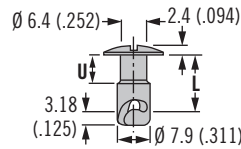
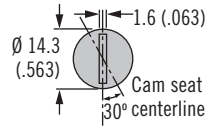

Hex Recess

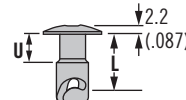
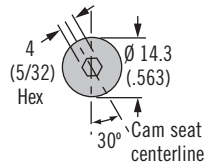

Phillips Recess

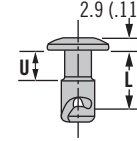
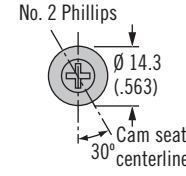

Flush slot

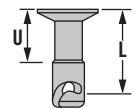
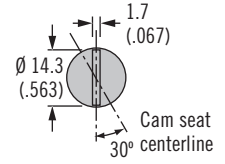

H Head Styles - Hand Actuated

Wing

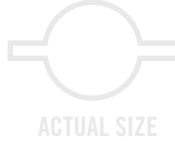
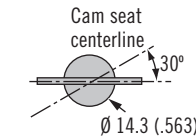

Bail

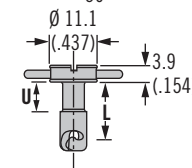
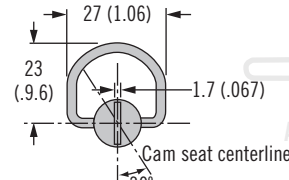

Stud Length Table										
A				B				U	L	K
TMT Range For: Rivet-On Receptacle D4-S5-225		TMT Range For: Rivet-On Receptacle D4-S5-200		TMT Range For: Weld-On Receptacle D4-X414-310		TMT Range For: Weld-On Receptacle D4-X414-285				
Min.	Max.	Min.	Max.	Min.	Max.	Min.	Max.			
2.67 (.105)	3.28 (.129)	3.3 (.13)	3.91 (.154)	~	~	~	~	3.18 (.125)	7.62 (.300)	30
3.94 (.155)	4.55 (.179)	4.57 (.18)	5.18 (.204)	1.65 (.065)	2.26 (.089)	2.29 (.09)	2.9 (.114)		8.89 (.350)	35
5.21 (.205)	5.82 (.229)	5.84 (.23)	6.45 (.254)	2.92 (.115)	3.53 (.139)	3.56 (.14)	4.17 (.164)	4.83 (.200)	10.16 (.400)	40
6.48 (.255)	7.09 (.279)	7.11 (.28)	7.72 (.304)	4.19 (.165)	4.8 (.189)	4.83 (.19)	5.44 (.214)		11.43 (.450)	45
7.75 (.305)	8.36 (.329)	8.38 (.33)	8.99 (.354)	5.46 (.215)	6.07 (.239)	6.1 (.24)	6.71 (.264)	6.35 (.250)	12.70 (.500)	50
9.02 (.355)	9.63 (.379)	9.65 (.38)	10.26 (.404)	6.73 (.265)	7.34 (.289)	7.37 (.29)	7.98 (.314)	6.99 (.275)	13.97 (.550)	55
10.29 (.405)	10.9 (.429)	10.92 (.43)	11.53 (.454)	8.00 (.315)	8.61 (.339)	8.64 (.34)	9.25 (.364)	7.62 (.300)	15.24 (.600)	60
11.56 (.455)	12.17 (.479)	12.19 (.48)	12.8 (.504)	9.27 (.365)	9.88 (.389)	9.91 (.39)	10.52 (.414)	8.89 (.350)	16.51 (.650)	65
12.83 (.505)	13.44 (.529)	13.46 (.53)	14.07 (.554)	10.54 (.415)	11.15 (.439)	11.18 (.44)	11.79 (.464)	10.16 (.400)	17.78 (.700)	70
14.1 (.555)	14.71 (.579)	14.73 (.58)	15.34 (.604)	11.81 (.465)	12.42 (.489)	12.45 (.49)	13.06 (.514)		19.05 (.750)	75
15.37 (.605)	15.98 (.629)	16.00 (.63)	16.61 (.654)	13.08 (.515)	13.69 (.539)	13.72 (.54)	14.33 (.564)	12.7 (.500)	20.32 (.800)	80
16.64 (.655)	17.25 (.679)	17.27 (.68)	17.88 (.704)	14.35 (.565)	14.96 (.589)	14.99 (.59)	15.6 (.614)		21.59 (.850)	85
17.91 (.705)	18.52 (.729)	18.54 (.73)	19.15 (.754)	15.62 (.615)	16.23 (.639)	16.26 (.64)	16.87 (.664)	15.24 (.600)	22.86 (.900)	90
19.18 (.755)	19.79 (.779)	19.81 (.78)	20.42 (.804)	16.89 (.665)	17.5 (.689)	17.53 (.69)	18.14 (.714)		24.13 (.950)	95
20.45 (.805)	21.06 (.829)	21.08 (.83)	21.69 (.854)	18.16 (.715)	18.77 (.739)	18.8 (.74)	19.41 (.764)	17.78 (.70)	25.40 (1.00)	100

Flush

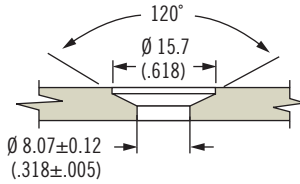

Standard

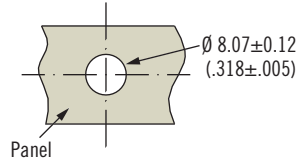

Part Number Selection

H Head style

- AJ Slot
- ASHJ Hex recess
- APRJ Phillips recess
- FJ Flush slot
- AJW Wing head
- BJR Bail head

K Length

Enter number from selection table below

M Material

SS Stainless steel
Omit for steel, zinc plated

D4 - H 5 - K M

Stud Length Table

TMT Range For: Clip-On Receptacle D4-SL5-305		TMT Range For: Clip-On Receptacle D5-SL5-280		U	L	K
Min.	Max.	Min.	Max.			
~	~	1.17 (.046)	1.78 (.07)	3.18 (.125)	7.62 (.300)	30
1.8 (.071)	2.41 (.095)	2.44 (.096)	3.05 (.12)		8.89 (.350)	35
3.07 (.121)	3.68 (.145)	3.71 (.146)	4.32 (.17)	4.83 (.200)	10.16 (.400)	40
4.34 (.171)	4.95 (.195)	4.98 (.196)	5.59 (.22)		11.43 (.450)	45
5.61 (.221)	6.22 (.245)	6.25 (.246)	6.86 (.27)	6.35 (.250)	12.70 (.500)	50
6.88 (.271)	7.49 (.295)	7.52 (.296)	8.13 (.32)	6.99 (.275)	13.97 (.550)	55
8.15 (.321)	8.76 (.345)	8.79 (.346)	9.4 (.37)	7.62 (.300)	15.24 (.600)	60
9.42 (.371)	10.03 (.395)	10.06 (.396)	10.67 (.42)	8.89 (.350)	16.51 (.650)	65
10.69 (.421)	11.3 (.445)	11.33 (.446)	11.94 (.47)	10.16 (.400)	17.78 (.700)	70
11.96 (.471)	12.57 (.495)	12.6 (.496)	13.21 (.52)		19.05 (.750)	75
13.23 (.521)	13.84 (.545)	13.87 (.546)	14.48 (.57)	12.7 (.500)	20.32 (.800)	80
14.5 (.571)	15.11 (.595)	15.14 (.596)	15.75 (.62)		21.59 (.850)	85
15.77 (.621)	16.38 (.645)	16.41 (.646)	17.02 (.67)	15.24 (.600)	22.86 (.900)	90
17.04 (.671)	17.65 (.695)	17.68 (.696)	18.29 (.72)		24.13 (.950)	95
18.31 (.721)	18.92 (.745)	18.95 (.746)	19.56 (.77)	17.78 (.70)	25.40 (1.00)	100

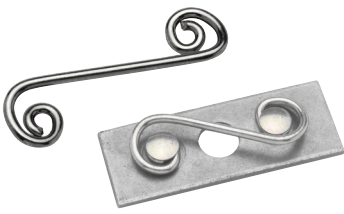

D4 DZUS® Standard Line Quarter-Turn Fasteners

Receptacles · Size 5

Material and Finish

Steel, zinc plated or stainless steel

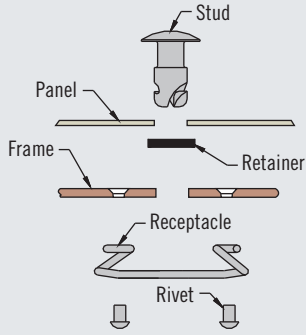

Part Number

See table

Notes

Utilize stud selection column indicated when choosing a stud length from the stud length table on pages 422-423

Rivet-On

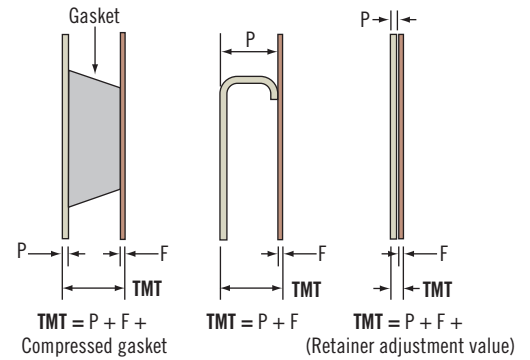
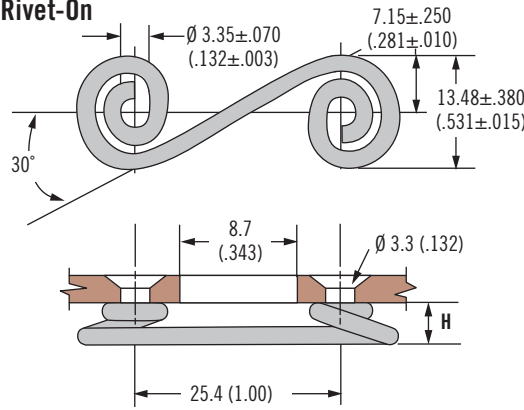

Part Number		H	Stud Selection Column
Steel	Stainless Steel		
D4-S5-200	D4-S5-200SS	5.08 (.200)	A
D4-S5-225	D4-S5-225SS	5.72 (.225)	

Material and Finish

Steel, zinc plated or stainless steel

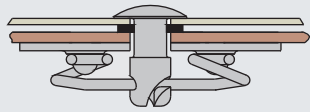

Weld-On

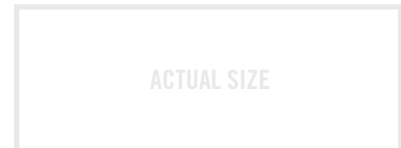
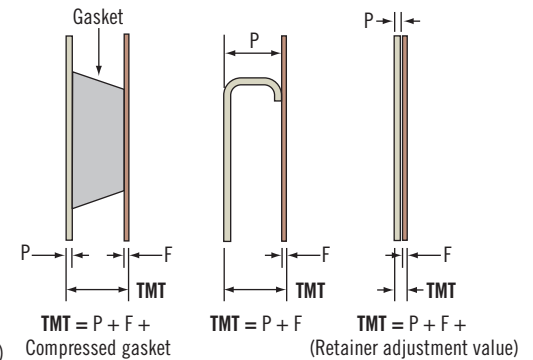
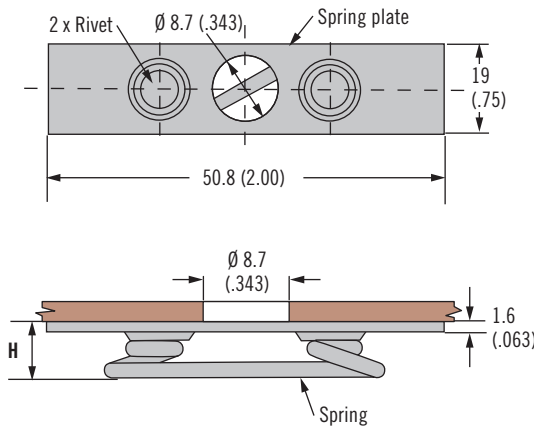

Part Number

See table

Notes

Utilize stud selection column indicated when choosing a stud length from the stud length table on pages 422-423

Part Number		H	Stud Selection Column
Steel	Stainless Steel		
D4-X414-285	D4-X414-285SS	7.2 (.285)	B
D4-X414-310	D4-X414-310SS	7.9 (.310)	



D4 DZUS® Standard Line Quarter-Turn Fasteners

Receptacles · Size 5



Clip-On

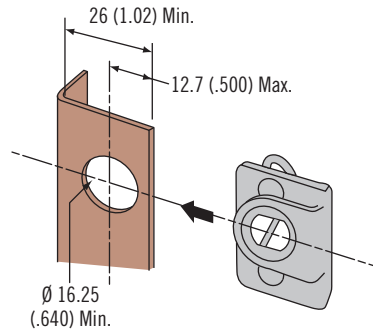
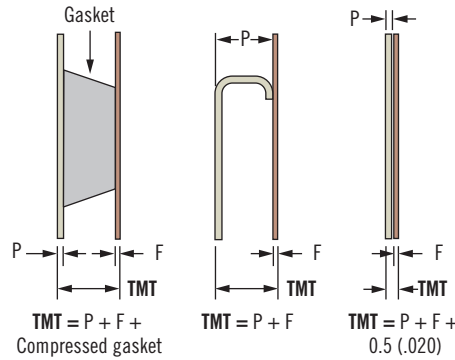
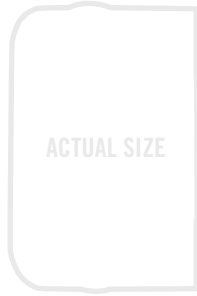
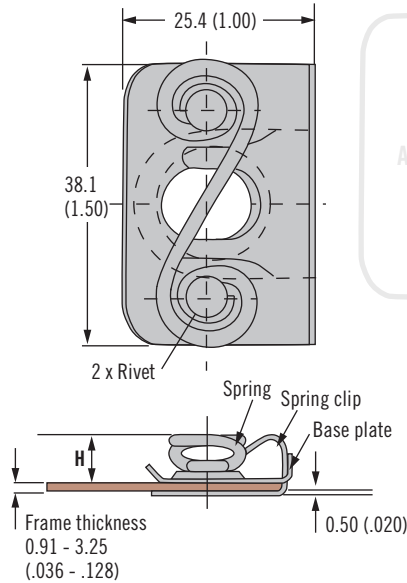

Note:
Panel misalignment can be tolerated by increasing the support hole to 17.86 (.703) and decreasing the hole center to edge distance to 11.43 (.450)

Part Number	H	Stud Selection Column
D4-SL5-280	7.11 (.280)	C
D4-SL5-305	7.75 (.305)	

Material and Finish

Steel, zinc plated

82

85

D8

D9

D1

D4

D5

D7

NY



Part Number

See table

Notes

Utilize stud selection column indicated when choosing a stud length from the stud length table on pages 422-423



D4 DZUS® Standard Line Quarter-Turn Fasteners

Stud selection · Size 6

Material and Finish

Studs:
Steel, zinc plated or stainless steel

82

85

D8

D9

D1

D4

D5

D7

NY

To select correct fastener:

1. Select receptacle

Choose a receptacle from page 427

2. Select retainer and accessories

from pages 416-417 and note any adjustment values

3. Specify stud length

Calculate the total material thickness (TMT) using the formula given for the receptacle selected. Find the range of TMT using the stud length selection table (right) using the column (A or B) given for the receptacle selected.

4. Complete the stud part number

by specifying the head style **H**, stud length **K**, and material **M**

Example:

For rivet-on

D4-S6-300 use column A

For TMT value calculated as 5.2 (.206), K = 45

For slotted head style in steel material, completed part number: D4-AJ6-45

A complete example can be found on page 377.

Notes

Stainless steel material may require a higher minimum order quantity. Contact Southco for details.

H Head Styles - Tool Actuated

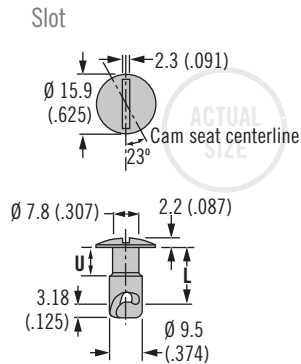

H Head Styles - Hand Actuated

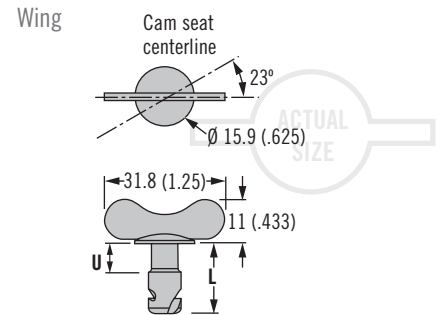

Flush

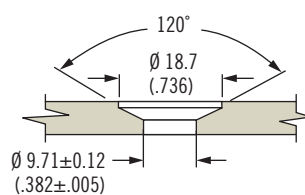

Standard

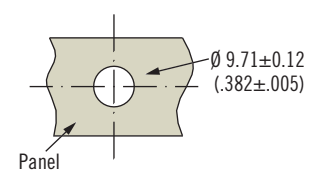

H Head style

- AJ Slot recess
- AJW Wing head
- FJ Flush slot

K Length

Enter number from selection table below

M Material

- SS Stainless steel
- Omit for steel, zinc plated

D4 - H 6 - K M

Stud Length Table										
A				B				U	L	K
TMT Range For: Rivet-On Receptacle D4-S6-300		TMT Range For: Rivet-On Receptacle D4-S6-275		TMT Range For: Weld-On Receptacle D4-X441-335		TMT Range For: Weld-On Receptacle D4-X441-310				
Min.	Max.	Min.	Max.	Min.	Max.	Min.	Max.			
2.29 (.090)	2.90 (.114)	2.92 (.115)	3.53 (.139)	1.40 (.055)	2.01 (.079)	2.03 (.080)	2.64 (.104)	4.45 (.175)	8.89 (.350)	35
3.56 (.140)	4.17 (.164)	4.19 (.165)	4.80 (.189)	2.67 (.105)	3.28 (.129)	3.30 (.130)	3.91 (.154)	5.08 (.200)	10.16 (.400)	40
4.83 (.190)	5.44 (.214)	5.46 (.215)	6.07 (.239)	3.94 (.155)	4.55 (.179)	4.57 (.180)	5.18 (.204)	5.72 (.225)	11.43 (.450)	45
6.10 (.240)	6.71 (.264)	6.73 (.265)	7.34 (.289)	5.21 (.205)	5.82 (.229)	5.84 (.230)	6.45 (.254)	6.35 (.250)	12.70 (.500)	50
7.37 (.290)	7.98 (.314)	8.00 (.315)	8.61 (.339)	6.48 (.255)	7.09 (.279)	7.11 (.280)	7.72 (.304)	6.99 (.275)	13.97 (.550)	55
8.64 (.340)	9.25 (.364)	9.27 (.365)	9.88 (.389)	7.75 (.305)	8.36 (.329)	8.38 (.330)	8.99 (.354)	7.62 (.300)	15.24 (.600)	60
9.91 (.390)	10.52 (.414)	10.54 (.415)	11.15 (.439)	9.02 (.355)	9.63 (.379)	9.65 (.380)	10.26 (.404)	8.89 (.350)	16.51 (.650)	65
11.18 (.440)	11.79 (.464)	11.81 (.465)	12.42 (.489)	10.29 (.405)	10.90 (.429)	10.92 (.430)	11.53 (.454)		17.78 (.700)	70
12.45 (.490)	13.06 (.514)	13.08 (.515)	13.69 (.539)	11.56 (.455)	12.17 (.479)	12.19 (.480)	12.80 (.504)	10.16 (.400)	19.05 (.750)	75
13.72 (.540)	14.33 (.564)	14.35 (.565)	14.96 (.589)	12.83 (.505)	13.44 (.529)	13.46 (.530)	14.07 (.554)	11.43 (.450)	20.32 (.800)	80
14.99 (.590)	15.60 (.614)	15.62 (.615)	16.23 (.639)	14.10 (.555)	14.71 (.579)	14.73 (.580)	15.34 (.604)	12.7 (.500)	21.59 (.850)	85
16.26 (.640)	16.87 (.664)	16.89 (.665)	17.50 (.689)	15.37 (.605)	15.98 (.629)	16.00 (.630)	16.61 (.654)	13.97 (.550)	22.86 (.900)	90
17.53 (.690)	18.14 (.714)	18.16 (.715)	18.77 (.739)	16.64 (.655)	17.25 (.679)	17.27 (.680)	17.88 (.704)	15.24 (.600)	24.13 (.950)	95
18.80 (.740)	19.41 (.764)	19.43 (.765)	20.04 (.789)	17.91 (.705)	18.52 (.729)	18.54 (.730)	19.15 (.754)	16.51 (.650)	25.40 (1.00)	100



D4 DZUS® Standard Line Quarter-Turn Fasteners

Receptacles · Size 6

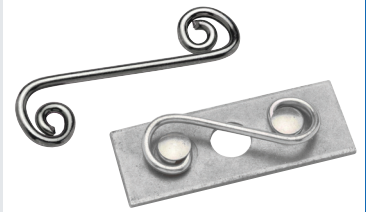

427

Rivet-On

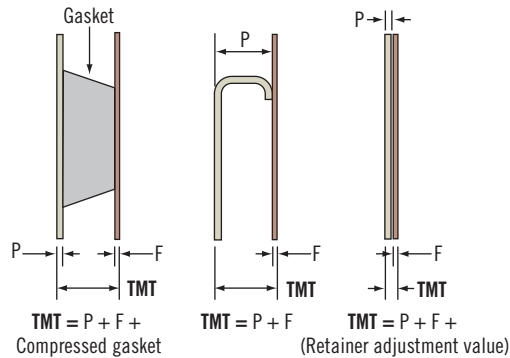
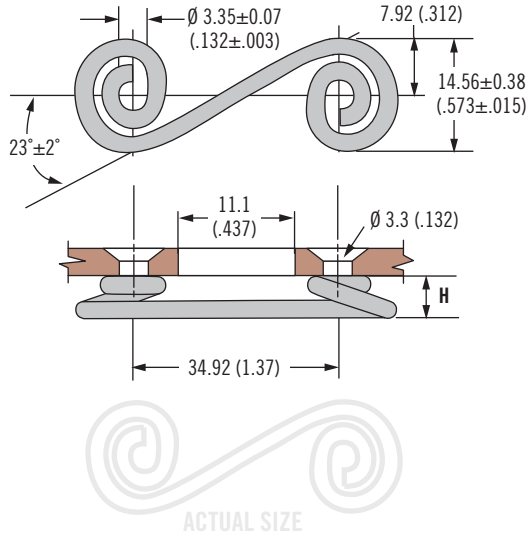

Part Number		H	Stud Selection Column
Steel	Stainless Steel		
D4-S6-275	D4-S6-275SS	6.99 (.275)	A
D4-S6-300	D4-S6-300SS	7.62 (.300)	

Material and Finish

Steel, zinc plated or stainless steel

Notes

After selecting receptacle use stud selection letter **A** and follow instruction on page 426

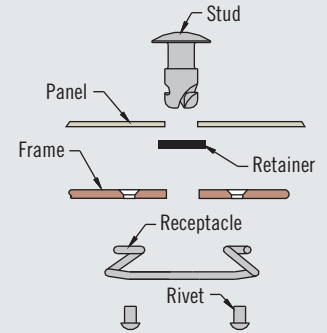

Part Number

See table

Weld-On

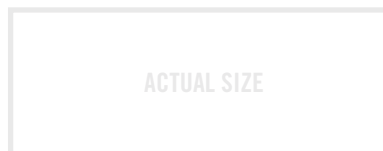
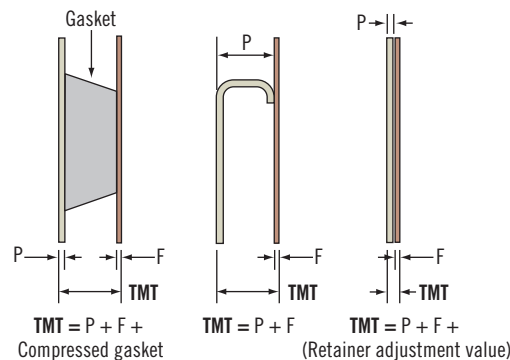
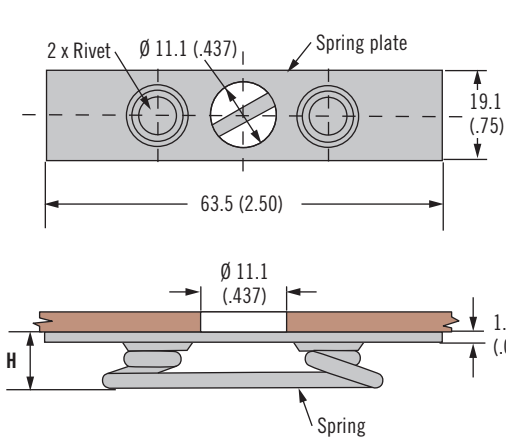

Part Number	H	Stud Selection Column
D4-X441-310	7.87 (.310)	B
D4-X441-335	8.51 (.335)	

Material and Finish

Steel, zinc plated

Notes

After selecting receptacle use stud selection letter **B** and follow instruction on page 426

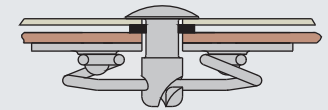

Part Number

See table

Installation Guidelines

for *SOUTHCO*® Self-Clinching products

Self-clinching product installation is offered on these *SOUTHCO*® products, making them easy-to-use captive panel fasteners:

- Captive Screws
- Receptacles for Quarter-turn Fasteners
- Receptacles for Fast-lead Thread Screws

When pressed into a properly prepared hole, self-clinching captive fasteners cold-flow (move) the panel material into the retaining groove of the fastener. This material then retains the fastener in the panel.

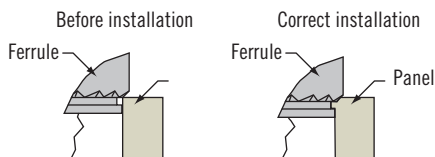

Successful press-in installations depend on:

Material:

The hardness of the panel material must not exceed *SOUTHCO*® recommendations. If the panel is too hard, the fastener will not install correctly.

Installation Holes:

Mounting holes may be drilled, punched, or cast.

- Hole edge: the top hole edge must be sharp but with no broken edges.

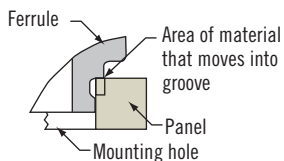

Do not chamfer or debur edge.

- Punched holes: use a punch and die with a small clearance to minimize the rollover and fracture angle.
- Hole diameter: measure the hole diameter at the panel surface on the side on which the fastener will be installed. The diameter must be within *SOUTHCO*® specifications for that product.

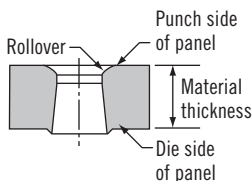

- If the hole is too large, not enough material will flow into the

retaining groove and the fastener may not be retained adequately.

- If the hole is too small, the fastener will not fit and installation may become difficult and unsafe.
- Hole distance from the edge of panel: the minimum recommended distance is 1.5 x the diameter of the mounting hole, unless otherwise indicated.

- Spring-loaded Plungers
- Captive Nuts
- Threaded Inserts

- Installing too close to the edge will cause the material to flow in the opposite direction, deforming the edge of the panel. To install closer to the edge, you may need to restrain the panel edge.

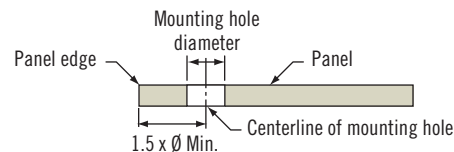

Panel Thickness:

The thickness of the panel at the mounting hole location must meet or exceed Southco's stated minimum recommendations.

If the material is too thin, panel deformation and/or damage to the fastener may result.

Installation is fast and easy if you follow these tips:

How to install: Use the recommended force where noted and a proper back-up tool.

- use any parallel-acting press
- use a punch whose diameter is larger than the head of the fastener

Installation Force: Proper installation requires an even distribution of adequate force. It does not depend on the distance the fastener is pressed into the panel.

- Southco does not recommend using a hammer. The impact force does not provide an even distribution of force to allow the panel material to completely flow into the fastener's retaining groove.
- Installation force varies from application to application, depending on the criteria noted above.
- On parts without a collar to provide a hard stop, press-in until the edge of the knurl is just barely visible.

When to Install:

Installation is recommended after plating or finishing has been applied to the panel.

The hole diameter must meet specifications before finish or plating is applied.

- Do not over-install parts. This interrupts the material and will reduce the retention strength.

