

REVISION HISTORY			
REV	DATE	BY	DESCRIPTION
C	19APR2013	BGL/DGJ	PRN: P2013-0845

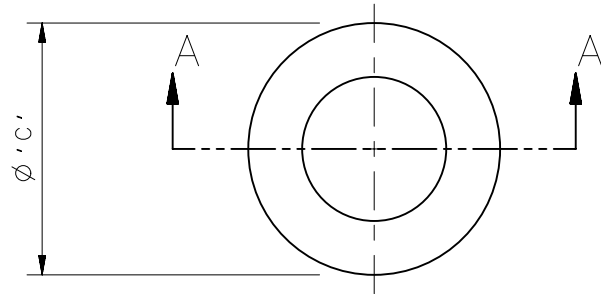

SCALE 1:1

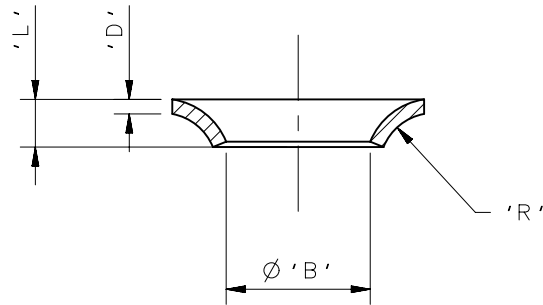

SECTION A-A

X = TYPE	'C'	'B'	'D'	'R'	'L'
3	7.9[.31]	4.8[.19]	.38[.01]	1.6[.062]	1.3[.05]
35	9.5[.37]	5.6[.22]	.64[.03]	2.0[.078]	1.5[.06]
4	11.1[.44]	6.35[.25]	.64[.03]	2.4[.1]	2.1[.08]
5	14.3[.56]	7.9[.31]	.88[.035]	6.35[.25]	2.7[.11]
6	15.9[.63]	9.5[.37]	.88[.035]	4.0[.16]	2.9[.11]
7	19.1[.75]	11.3[.44]	.90[.04]	5.5[.22]	2.8[.11]

D4-GHX	ALUMINUM	NATURAL
D4-GHXS	STEEL	ZINC PLATE PLUS CHROMATE
D4-GHXSS	STAINLESS STEEL	NATURAL
D4-GHXQA	ALUMINUM	NATURAL
PART NUMBER	MATERIAL	FINISH

THIS DRAWING SUPERCEDES DRAWING  
J-D4-GH3-6\_revA AND J-D4-GH3-7\_revA

<p>THIRD ANGLE PROJECTION</p> <p>MILLIMETERS [IN]</p> <p>TOLERANCES UNLESS OTHERWISE NOTED</p> <p>ALL DIMENSIONS WITHOUT TOLERANCES ARE FOR REFERENCE ONLY.</p> <p>PROPRIETARY ITEM EXCEPT FOR USES EXPRESSLY GRANTED IN WRITING, INFORMATION DISCLOSED HEREON IS CONFIDENTIAL AND ALL RIGHTS, PATENT AND OTHERWISE, ARE RESERVED BY SOUTHCO, INC.</p>	<p>DESCRIPTION</p> <p>GROMMET - GH SERIES</p>	
	<p>SIZE</p> <p>A4</p>	<p>SYSTEM</p> <p>NX</p>
	<p>DWG NO.</p> <p>J-D4-GH</p>	
	<p>PER ASME Y14.5M-1994</p>	<p>DRAWN BY</p> <p>YGC</p>
<p>SCALE</p> <p>3:1</p>		<p>SHEET</p> <p>1 OF 1</p>

**southco**<sup>®</sup>  
CONNECT • CREATE • INNOVATE