

REVISION HISTORY			
REV	DATE	BY	DESCRIPTION
A	04AUG2016	CMS/JW	PRN: P2016-1826

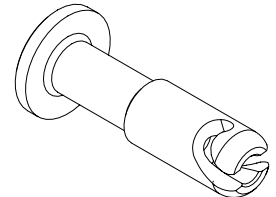

SCALE 2:1

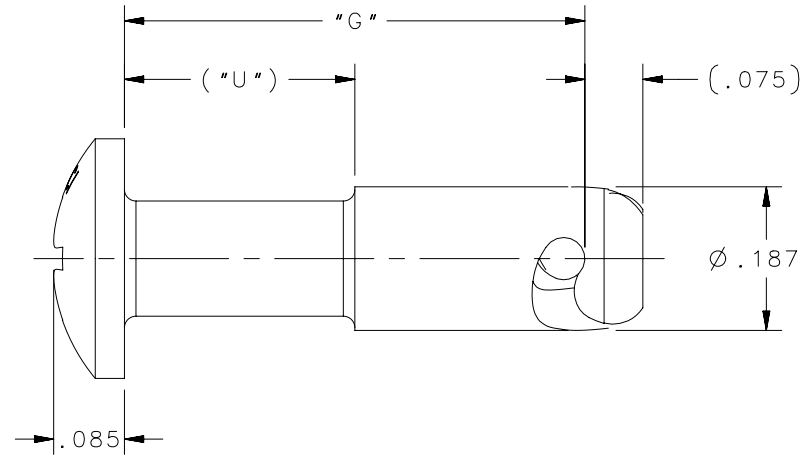
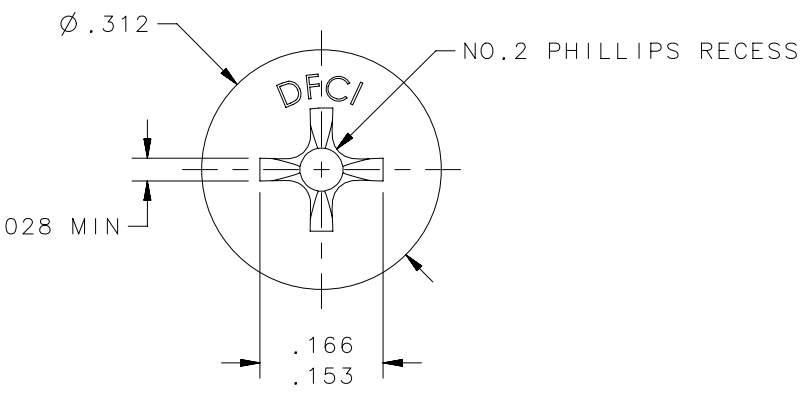

DFCI PART NO.	DZUS PART NO.	SOUTHCO PART NO.	DIM "G"	DIM "U"	MATERIAL	FINISH
121J-P325-14S-PAS	APRJ3-2514SSPS	D4-APRJ32514SSPSNA	0.250	0.075	SEE NOTE A	SEE NOTE C
121J-P325-Z3C	APRJ3-25ZBC	D4-APRJ3-25ZBCNA	0.025	0.075	SEE NOTE A	
121J-P325-Z3CT	APRJ3-25ZCT	D4-APRJ3-25ZCTNA	0.025	0.075	SEE NOTE A	
121J-P330-Z3C	APRJ3-30ZBC	D4-APRJ3-30ZBCNA	0.300	0.100	SEE NOTE A	
121J-P330-Z3CT	APRJ3-30ZCT	D4-APRJ3-30ZCTNA	0.300	0.100	SEE NOTE A	
121J-P340-NBO	APRJ3-40NBB	D4-APRJ3-40NBBNA	0.400	0.200	SEE NOTE A	
121J-P325-SS	APRJ3-25SS	D4-APRJ3-25SSNA	0.025	0.075	SEE NOTE B	
121J-P330-SS	APRJ3-30SS	D4-APRJ3-30SSNA	0.300	0.100	SEE NOTE B	
121J-P335-SS	APRJ3-35SS	D4-APRJ3-35SSNA	0.350	0.150	SEE NOTE B	
121J-P340-SS	APRJ3-40SS	D4-APRJ3-40SSNA	0.400	0.200	SEE NOTE B	
121J-P340-SS-BOF	APRJ3-40SSBA	D4-APRJ3-40SSBANA	0.400	0.200	SEE NOTE B	
121J-P350-SS-BOF	APRJ3-50SSBA	D4-APRJ3-50SSBANA	0.500	0.250	SEE NOTE B	
121J-P375-SS	APRJ3-75SS	D4-APRJ3-75SSNA	0.750	0.400	SEE NOTE B	

NOTES:

- A. AISI 10B21 OR 8620 STEEL, HEAT TREATED TO ROCKWELL C30-38.
- B. 303 STAINLESS STEEL.
- C. PLEASE REFER TO J-D5-0-3 FOR FINISH INFORMATION AND SPECIFICATIONS.

THIRD ANGLE PROJECTION		 CONNECT • CREATE • INNOVATE			
INCHES [MM]					
TOLERANCES UNLESS OTHERWISE NOTED		DESCRIPTION PHILLIPS RECESS HEAD STUD			
ALL DIMENSIONS WITHOUT TOLERANCES ARE FOR REFERENCE ONLY.		SIZE A	SYSTEM NX	DWG NO. J-D4-APRJ3NA	
PER ASME Y14.5M-1994		DRAWN BY CMS/JW	DATE 04AUG2016	SCALE 4:1	SHEET 1 OF 1

PROPRIETARY ITEM
EXCEPT FOR USES EXPRESSLY GRANTED IN WRITING, INFORMATION DISCLOSED HEREON IS CONFIDENTIAL AND ALL RIGHTS, PATENT AND OTHERWISE, ARE RESERVED BY SOUTHCO, INC.