

southco

PROPRIETARY ITEM - EXCEPT FOR USES EXPRESSLY GRANTED IN WRITING INFORMATION DISCLOSED HEREON IS CONFIDENTIAL AND ALL RIGHTS PATENT AND OTHERWISE ARE RESERVED BY SOUTHCO, INC.

TITLE STANDARD LINE FASTENER SIZE 4 PHILLIPS RECESS HEAD

DATE 20-11-07 DRAWN MJW CHKD SCALE 5:1

DRAWING NUMBER J-D4-APRJ4

REV	DATE	DRAWN/CHKD	DESCRIPTION	PART NUMBER	MATERIAL	FINISH
A	20-09-08	M Waldren	PRN P2008-0521	D4-APRJ4-XX	CARBON STEEL	ZINC & CLEAR PASSIVATION
				D4-APRJ4-XX OA	CARBON STEEL	CADMIUM PLATE
				D4-APRJ4-XX SS	STAINLESS STEEL	CLEAN

MILLIMETERS

ALL UNTOLERANCED DIMENSIONS ARE FOR REFERENCE

THIRD ANGLE PROJECTION A3 PAPER SIZE # INDICATES DIMENSION WITH SIGNIFICANT CHARACTERISTIC FILE No. XX

Obsolete Drawingsee Dwg J-D4-J4....21APR2010.....JCG

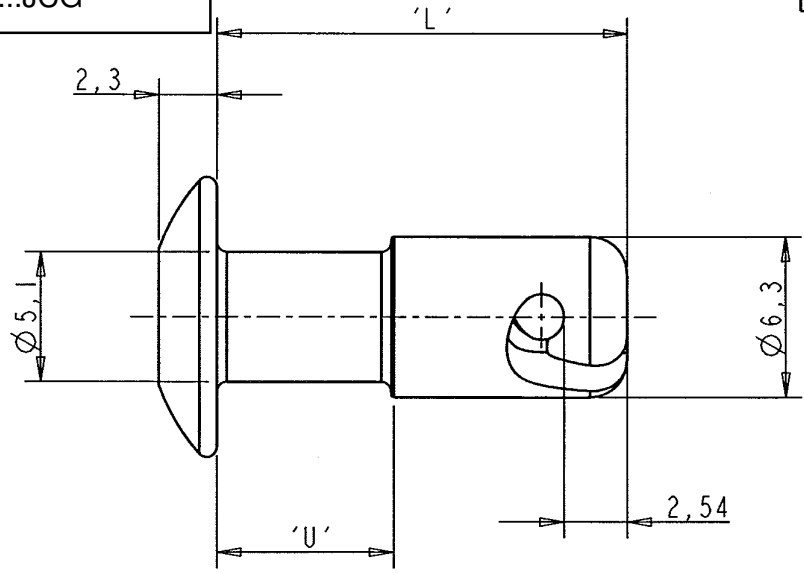
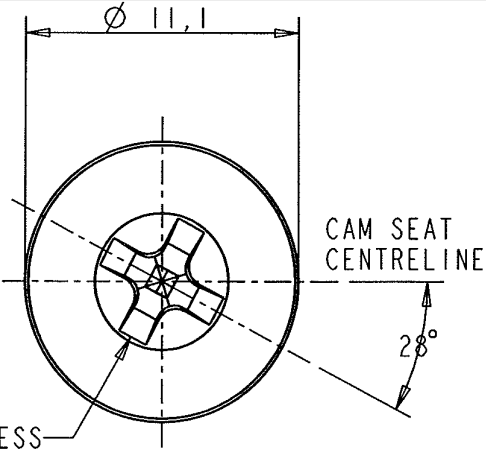

PART No.	'L'	'U'	PART No.	'L'	'U'	PART No.	'L'	'U'
D4-APRJ4-30	7,62	3,81	D4-APRJ4-120	30,48	15,24	D4-APRJ4-210	53,34	15,24
D4-APRJ4-35	8,89	3,81	D4-APRJ4-125	31,75	15,24	D4-APRJ4-215	54,61	15,24
D4-APRJ4-40	10,16	5,08	D4-APRJ4-130	33,02	15,24	D4-APRJ4-220	55,88	15,24
D4-APRJ4-45	11,43	5,77	D4-APRJ4-135	34,29	15,24	D4-APRJ4-225	57,15	15,24
D4-APRJ4-50	12,70	6,35	D4-APRJ4-140	35,56	15,24	D4-APRJ4-230	58,42	15,24
D4-APRJ4-55	13,97	6,99	D4-APRJ4-145	36,83	15,24	D4-APRJ4-235	59,69	15,24
D4-APRJ4-60	15,24	7,62	D4-APRJ4-150	38,10	15,24	D4-APRJ4-240	60,96	15,24
D4-APRJ4-65	16,51	8,89	D4-APRJ4-155	39,37	15,24	D4-APRJ4-245	62,23	15,24
D4-APRJ4-70	17,78	8,89	D4-APRJ4-160	40,64	15,24	D4-APRJ4-250	63,50	15,24
D4-APRJ4-75	19,05	10,16	D4-APRJ4-165	41,91	15,24			
D4-APRJ4-80	20,32	10,16	D4-APRJ4-170	43,18	15,24			
D4-APRJ4-85	21,59	12,70	D4-APRJ4-175	44,45	15,24			
D4-APRJ4-90	22,86	12,70	D4-APRJ4-180	45,72	15,24			
D4-APRJ4-95	24,13	15,24	D4-APRJ4-185	46,99	15,24			
D4-APRJ4-100	25,40	15,24	D4-APRJ4-190	48,26	15,24			
D4-APRJ4-105	26,67	15,24	D4-APRJ4-195	49,53	15,24			
D4-APRJ4-110	27,94	15,24	D4-APRJ4-200	50,80	15,24			
D4-APRJ4-115	29,21	15,24	D4-APRJ4-205	52,07	15,24			

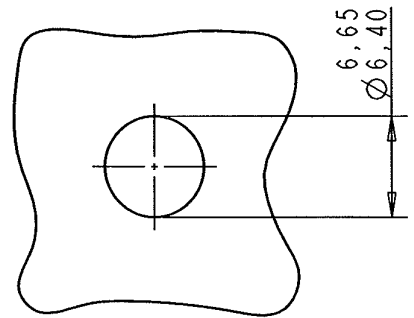

STANDARD PANEL PREPARATION