

Zinc die-cast lift-off hinges 64 x 50 mm

Nylon washer.
Steel pin.

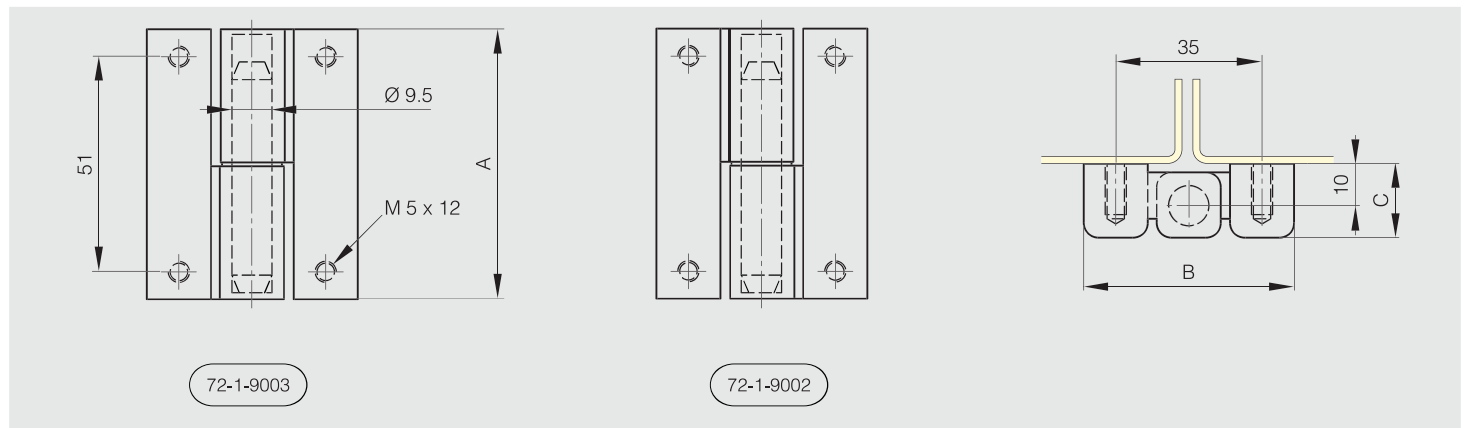

Part number	Material	Finish	A	B	C	Note	Weight (g)
72-1-9002	zinc die-cast	black	64	50	17.5	type 2	243
72-1-9003	zinc die-cast	black	64	50	17.5	type 1	247



Zinc die-cast lift-off hinges 80 mm

Fixing by 2 threaded studs. Stainless steel pin.
Leaves blocked with grub screw. Unscrew it to get a lift-off hinge.



Part number	Material	Finish	A	B	C	D	G	Note	Weight (g)
14-7-3813	zinc die-cast	black	80	65	8	8	60	type 2	330
14-7-3814	zinc die-cast	black	80	65	8	8	60	type 1	330

