

Spring hinges - aluminium profile 0.35 N.m - diameter 13



Opening spring force:

M(0°): 0.35 N.m / M(90°): 0.24 N.m / M(180°): 0.12 N.m

Closing spring force:

M(0°): 0.12 N.m / M(90°): 0.24 N.m / M(180°): 0.35 N.m

3 other versions available: free swinging, with friction or with detent mechanism.



| Part number | Material | Finish | A | B | C | D | Note | Weight (g) |
|---------------|-------------|-----------------|----|----|-----|----|---|------------|
| 72-1-4220 | 6060 T5 alu | clear anodised | 67 | 55 | 4.5 | 13 | opening spring | 62 |
| 72-1-4221 | 6060 T5 alu | black anodised | 67 | 55 | 4.5 | 13 | opening spring | 60 |
| 72-1-4292 | 6060 T5 alu | clear anodised | 67 | 55 | 4.5 | 13 | opening spring/ delivered flat | 63 |
| 72-1-4293 | 6060 T5 alu | black anodised | 67 | 55 | 4.5 | 13 | opening spring/ delivered flat | 63 |
| NS 72-1-4366 | 6060 T5 alu | blue anodised | 67 | 55 | 4.5 | 13 | opening spring/ delivered flat | 60 |
| NS 72-1-4367 | 6060 T5 alu | red anodised | 67 | 55 | 4.5 | 13 | opening spring/ delivered flat | 60 |
| NS 72-1-4368 | 6060 T5 alu | bronze anodised | 67 | 55 | 4.5 | 13 | opening spring/ delivered flat | 60 |
| NS 72-1-4369 | 6060 T5 alu | gold anodised | 67 | 55 | 4.5 | 13 | opening spring/ delivered flat | 60 |
| NEW 72-1-4323 | 6060 T5 alu | clear anodised | 67 | 55 | 4.5 | 13 | opening spring / delivered flat / with M6 studs | 80 |
| NEW 72-1-4324 | 6060 T5 alu | black anodised | 67 | 55 | 4.5 | 13 | opening spring / delivered flat / with M6 studs | 80 |
| 72-1-4286 | 6060 T5 alu | clear anodised | 67 | 55 | 4.5 | 13 | closing spring | 63 |
| 72-1-4287 | 6060 T5 alu | black anodised | 67 | 55 | 4.5 | 13 | closing spring | 63 |
| NS 72-1-4370 | 6060 T5 alu | blue anodised | 67 | 55 | 4.5 | 13 | closing spring | 60 |
| NS 72-1-4371 | 6060 T5 alu | red anodised | 67 | 55 | 4.5 | 13 | closing spring | 60 |
| NS 72-1-4372 | 6060 T5 alu | bronze anodised | 67 | 55 | 4.5 | 13 | closing spring | 60 |
| NS 72-1-4373 | 6060 T5 alu | gold anodised | 67 | 55 | 4.5 | 13 | closing spring | 60 |
| NS 72-1-4336 | 6060 T5 alu | clear anodised | 67 | 55 | 4.5 | 13 | closing spring / with M6 studs | 79 |
| NS 72-1-4337 | 6060 T5 alu | black anodised | 67 | 55 | 4.5 | 13 | closing spring / with M6 studs | 79 |

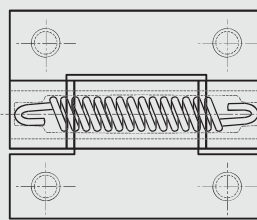
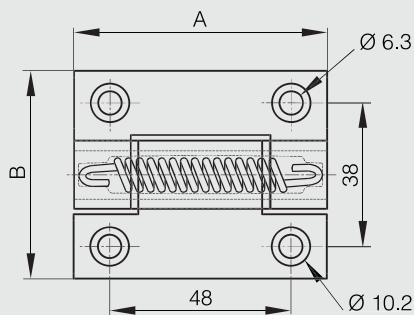

72-1-4323 & 72-1-4324
72-1-4336 & 72-1-4337

